

MISSION-CRITICAL
INTERCONNECT
SOLUTIONS

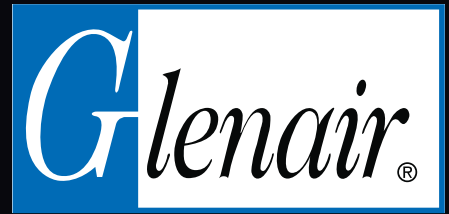

Glennair
SIGNATURE SERIES

High-Speed Interconnect Solutions

Rugged Electrical, Optical, and Hybrid Solutions for
Mission-Critical Aerospace and Defense Applications



Rugged High-Speed Interconnect Solutions

Electrical, Optical, and Hybrid Solutions for Mission-Critical Aerospace and Defense Applications

EL OCHITO[®] HIGH-SPEED OCTAXIAL CONTACTS AND CONNECTOR PACKAGING

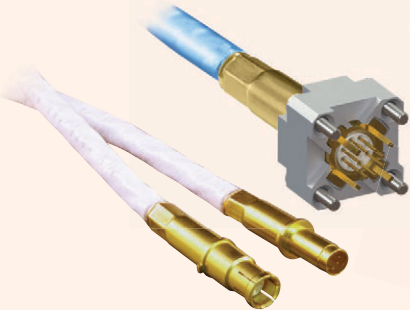

El Ochito[®] high-speed octaxial contacts



SuperFly nano miniature with El Ochito[®]



Series 792 micro miniature with El Ochito[®]



Series 806 Mil-Aero micro miniature with El Ochito[®]

EL OCHITO[®] PACKAGING (continued)



Series 23 SuperNine[®] with El Ochito[®]

SIGNATURE HIGH-SPEED CONNECTOR SOLUTIONS



Series 23 SuperNine[®] with SpeedMaster[™] 10G high-speed contacts



OctoByte[™] industrial-strength Ethernet connectors

SIGNATURE HIGH-SPEED CONNECTOR SOLUTIONS (continued)



SuperSeal[™] RJ45 Ethernet and USB ruggedized field connectors

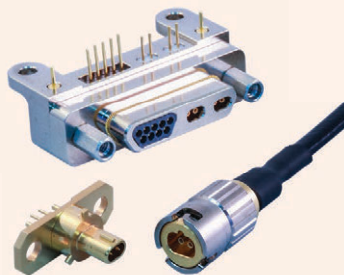

Micro-D form-factor connector with VersaLink[™] differential Twinax *plus* VersaLink[™] Bridge

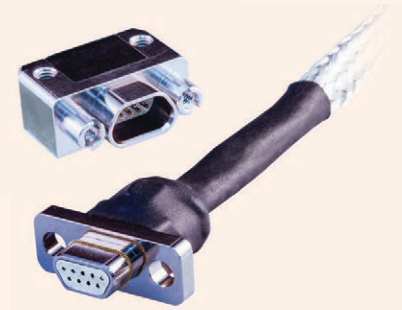

High-Speed Micro-D high-density SWaP solution

GLENAIR SIGNATURE BUTT-JOINT FIBER OPTIC INTERCONNECT SOLUTIONS



Rugged MIL-DTL-38999 type fiber optic

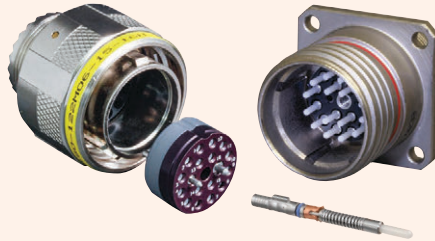

Glenair High Density (GHD) rugged fiber optic



Glenair Front Release (GFR) rugged fiber optic

SIGNATURE FIBER OPTIC SOLUTIONS (continued)



Rugged MT Ferrule solutions for 38999 and Series 791

RUGGED HIGH-SPEED ELECTRICAL-OPTICAL MEDIA CONVERTERS



Copper-to-fiber media converters for video applications



Copper-to-fiber media converters for Ethernet applications

RUGGED PCB-MOUNT TRANSCEIVERS FOR ETHERNET, HIGH-SPEED VIDEO, AND STORAGE

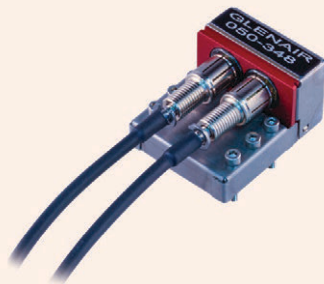

EMI shielded and radiation-tolerant transceivers

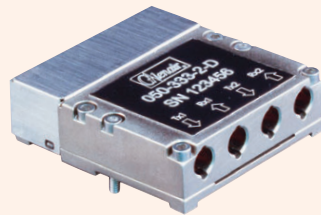

Dual transceivers, quad transmitters, quad receivers



Bi-directional transceivers

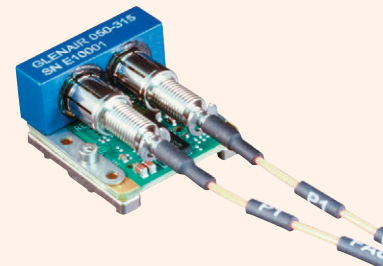

Small form-factor, high-vibration, high-temperature tolerant

RF-OVER FIBER AND HIGH-DATARATE PARALLEL OPTICAL TRANSCEIVERS



RF-over-fiber low-noise PCB-mount transceiver

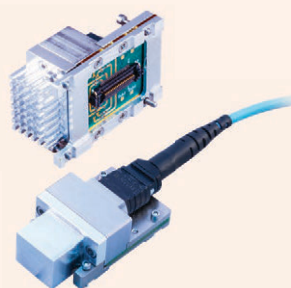

Parallel optical 40 Gb/s PCB-mount transceivers

SIZE #8 PHOTONIC TRANSMITTER AND RECEIVER CONTACTS FOR HIGH-SPEED DATA



Opto-electronic receptacle connectors populated with Size #8 Photonic transmitter and receiver contacts

HIGH-SPEED
OCTAXIAL
CONTACTS

El Ochito®

High-speed octaxial contacts for Ethernet,
SuperSpeed USB and multi-gigabit datalinks

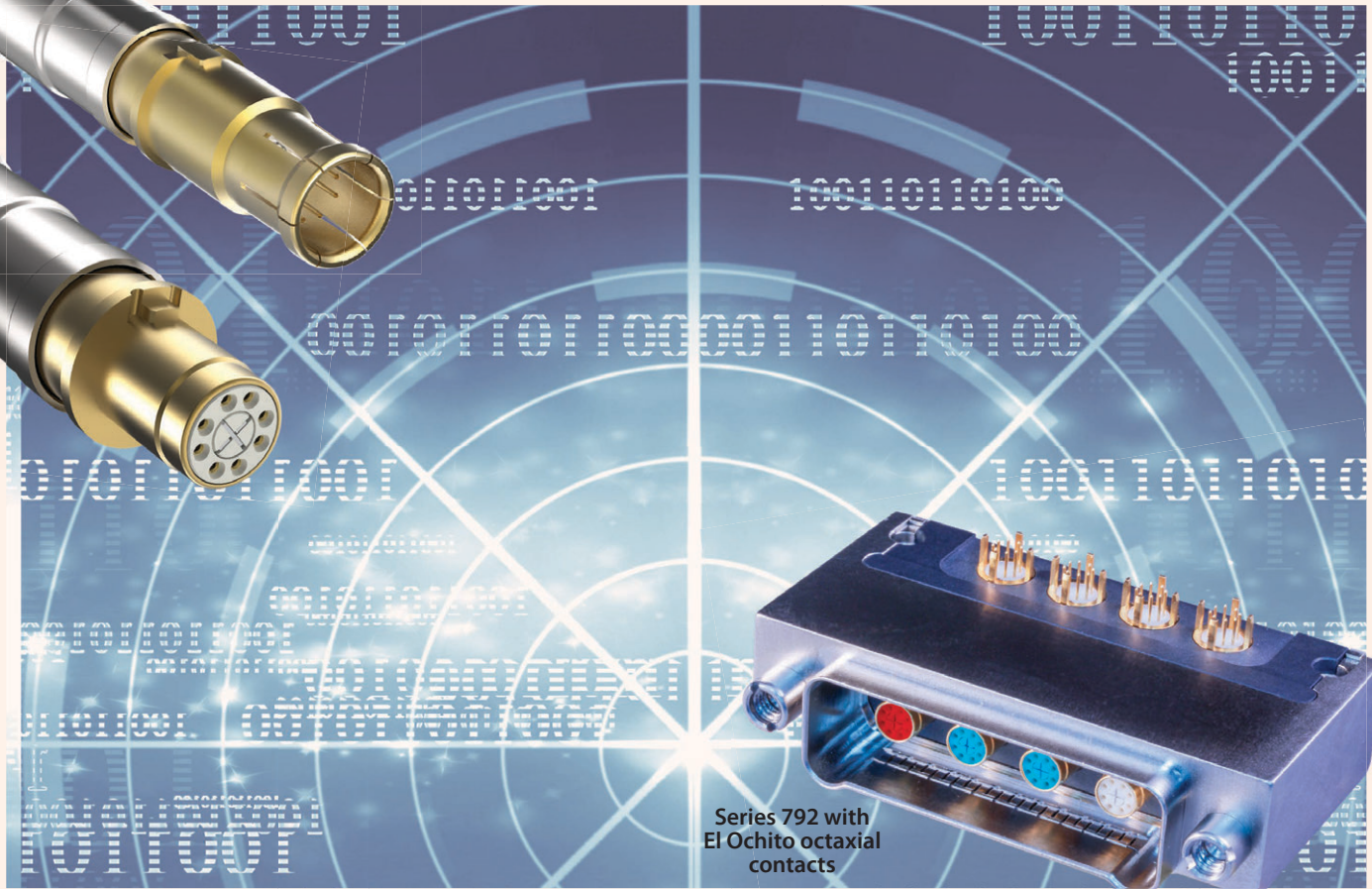
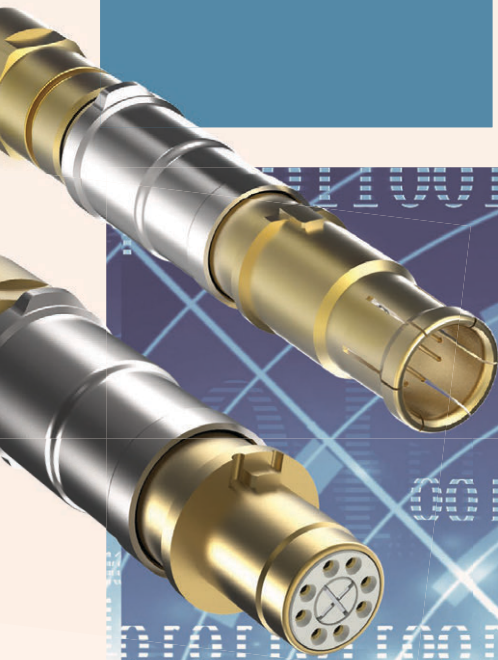

Series 792 with
El Ochito octaxial
contacts

High speed, harsh environment El Ochito® octaxial contacts save size and weight in aircraft avionics, weapons systems, satellites, radars, and communications equipment.

AVAILABLE SIGNATURE CONNECTOR PACKAGING INCLUDES



SuperFly
Nanominiature

806 Mil-Aero
Micro miniature

SuperNine
"Better than QPL" 38999

- 10GbE, SuperSpeed USB, and multi-gigabit shielded pairs
- Universal drop-in for keyed size #8 connector cavities
- Data-pair isolation for optimal signal integrity
- Crimp or threaded shield termination contact types
- Snap-in, rear release
- Environmentally sealed
- Aerospace-grade cable assemblies
- 50% cable / contact reduction compared to Quadrax

HIGH-SPEED OCTAXIAL El Ochito® Contacts



Protocols, exploded views of Type I and Type II contacts

El Ochito® White



1000BASE-T, 10GBASE-T

El Ochito® White octaxial contacts provide 10GbE in a single size #8 contact cavity (compared to two Quadrax) for 100BASE-T solutions.

El Ochito® Blue



SuperSpeed USB

Low-dielectric material. 90 ohms. El Ochito® Blue octaxial contacts provide an aerospace-grade solution for SuperSpeed USB 3.0

El Ochito® Red



HDMI, DisplayPort, SATA

Low-dielectric material. Up to 5 Gbps. 100 ohms. El Ochito® Red octaxial contacts provide an aerospace-grade solution for multi-gigabit data rates.

El Ochito® Type I Contacts, Non-Serviceable 26 AWG, Crimp Wire Shield Termination

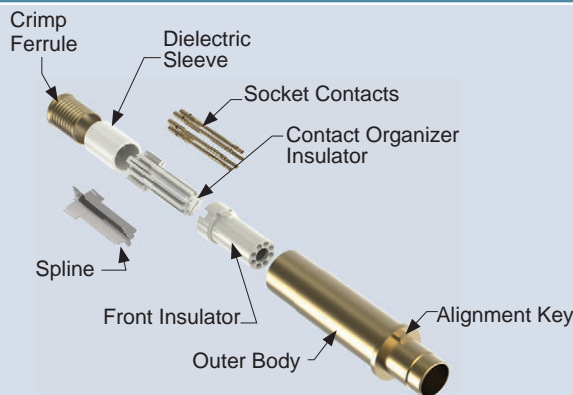

Type I Pin Contact

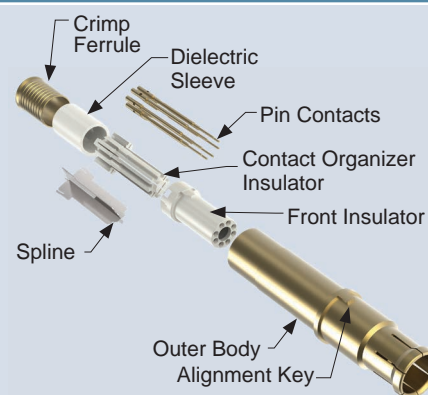

Type I Socket Contact

El Ochito® Type II Contacts, Serviceable

24-26 AWG, Threaded Wire Shield Termination, Integral Contact Release Sleeve

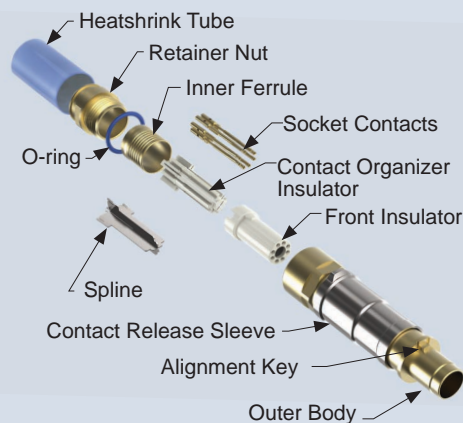

Type II Pin Contact

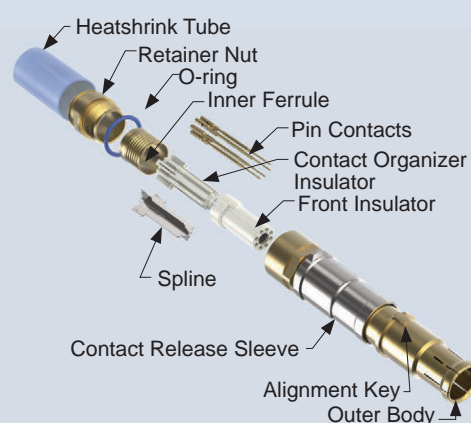

Type II Socket Contact

HIGH-SPEED OCTAXIAL El Ochito® White Contacts



How To Order

El Ochito® Contacts: How To Order								
					Data Protocol: 10G Ethernet El Ochito® White			
Connector Type	Wire Size	Cable Type	Cable		El Ochito® Type I		El Ochito® Type II	
			Glenair Part No. <i>(Mfr. P/N)</i>	Cable Dia.	Pin Contact <i>Assembly Instr.</i>	Sket Contact <i>Assembly Instr.</i>	Pin Contact <i>Assembly Instr.</i>	Sket Contact <i>Assembly Instr.</i>
ARINC 600	26	S/UTP	963-003-26 (PIC E6A3826)	.220 (5.56)	858-009-01 AI85074-01	858-010-01 AI85074-01		
		S/FTP	963-033-26 (Gore RCN9047-26)	.220 (5.56)	858-009-02 AI85084-01	858-010-02 AI85084-01		
Series 23 SuperNine®	24	S/UTP	963-037-24	.260 (6.60)			858-005-03 AI85097-03	858-006-03 AI85097-03
		S/FTP	963-033-24	.260 (6.60)			858-005-04 AI85097-04	858-006-04 AI85097-04
Series 801 and 805 Mighty Mouse	26	S/UTP	963-003-26 (PIC E6A3826)	.220 (5.56)	858-003-01F AI85048-01	858-004-01F AI85048-01	858-005-01 AI85097-01	858-006-01 AI85097-01
		S/FTP	963-033-26 (Gore RCN9047-26)	.220 (5.56)	858-003-02F AI85048-02	858-004-02F AI85048-02	858-005-02 AI85097-01	858-006-02 AI85097-01
Series 792	24		963-037-24 (PIC E6A3824)	.260 (6.60)			858-043-03 AI85134-03	858-042-03 AI85134-03
			963-033-24 (Gore RCN9047-24)	.260 (6.60)			858-043-04 AI85134-04	858-042-04 AI85134-04
	26	S/UTP	963-003-26 (PIC E6A3826)	.220 (5.56)	858-045-01F AI85048-01	858-046-01F AI85048-01	858-043-01 AI85134-01	858-042-01 AI85134-01
		S/FTP	963-033-26 (Gore RCN9047-26)	.220 (5.56)	858-045-02F AI85048-02	858-046-02F AI85048-02	858-043-02 AI85134-02	858-042-02 AI85134-02
Series 806	24	S/UTP	963-037-24 (PIC E6A3824)	.260 (6.60)			858-051-03 AI85149-03	858-052-03 AI85149-03
		S/FTP	963-033-24 (Gore RCN9047-24)	.260 (6.60)			858-051-04 AI85149-04	858-052-04 AI85149-04
	26	S/UTP	963-003-26 (PIC E6A3826)	.220 (5.56)	858-045-01F AI85048-01	858-046-01F AI85048-01	858-051-01 AI85149-01	858-052-01 AI85149-01
		S/FTP	963-033-26 (Gore RCN9047-26)	.220 (5.56)	858-045-02F AI85048-02	858-046-02F AI85048-02	858-051-02 AI85149-02	858-052-02 AI85149-02
EPXB	26	S/UTP	963-003-26 (PIC E6A3826)	.220 (5.56)	858-014-02F AI85099-01	858-015-02F AI85099-01		
		S/FTP	963-033-26 (Gore RCN9047-26)	.220 (5.56)	858-014-01F AI85105-01	858-015-01F AI85105-01		

HIGH-SPEED OCTAXIAL El Ochito® Blue and Red Contacts



How To Order

El Ochito® Contacts: How To Order



Data Protocol: SuperSpeed USB El Ochito® Blue

Connector Type	Wire Size	Cable Type	Cable		El Ochito® Type I	
			Glenair Part No.	Cable Dia.	Pin Contact Assembly Instr.	Socket Contact Assembly Instr.
Series 792 and 806	26	Commercial Grade (PVC Jacket)	963-118	.217 (5.51)	858-047-01F AI85114-02	858-048-01F AI85114-02
		Aerospace Grade (Fluoropolymer Jacket)	963-110	.236 (5.99)	858-047-02F AI85090-01	858-048-02F AI85090-01
Series 23 SuperNine® Series 801 and 805 Mighty Mouse Series 28 HiPer-D®	26	Commercial Grade (PVC Jacket)	963-118	.217 (5.51)	858-028-01F AI85114-02	858-029-01F AI85114-02
		Aerospace Grade (Fluoropolymer Jacket)	963-110	.236 (5.99)	858-028-02F AI85090-01	858-029-02F AI85090-01
ARINC 600	26	Commercial Grade (PVC Jacket)	963-118	.217 (5.51)	858-038-01 AI85124-01	858-035-01 AI852124-01
		Aerospace Grade (Fluoropolymer Jacket)	963-110	.236 (5.99)	858-038-02 AI85124-02	858-035-02 AI85124-02



Data Protocol: HDMI/SATA/DisplayPort/General High-Speed El Ochito® Red

Connector Type	Wire Size	Cable Type	Cable		El Ochito® Type I	
			Glenair Part No.	Cable Dia.	Pin Contact Assembly Instr.	Socket Contact Assembly Instr.
Series 792 and 806	26	4 Pair S/FTP	1Gb/s and above 963-122-X*	.299 (7.59)	858-049-01F* AI85048-02	858-050-01F* AI85048-02
Series 23 SuperNine® Series 801 and 805 Mighty Mouse Series 28 HiPer-D®			Up to 1Gb/s 963-033-26	.220 (5.56)	858-030-02F* AI85048-02	858-031-02F* AI85048-02
ARINC 600			HDMI/Display Port 963-120-X* 963-127-X*	.429 (10.9) .330 (8.38)	858-039-01 AI85084-01	858-037-01 AI85084-01
Series 792 and 806	26	Parallel Pair Twinax	SATA 963-043-26 [2 pcs.]	.116 x .071 (2.95 x 1.80)	858-049-02 AI85084-02	858-050-02 AI85084-02
Series 23 SuperNine® Series 801 and 805 Mighty Mouse Series 28 HiPer-D®					858-030-03 AI85084-03	858-031-03 AI85084-03
ARINC 600					858-039-02 AI85084-02	858-037-02 AI85084-02

* Omit F when using this cable

HIGH-SPEED
ULTRA
MINIATURE
I/O DATALINKS

SUPERFLY[®] DATALINK

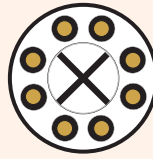

The Nano Miniature 10G Ethernet, USB 3.0,
and DisplayPort Connector with EI Ochito[®]
Octaxial Contact Technology



High speed, harsh environment SuperFly[®] Datalink connectors—
with shielded EI Ochito[®] octaxial contacts for 10Gb Ethernet,
SuperSpeed USB, and high data rate video display protocols—
deliver outstanding signal integrity and save significant size and
weight compared to Quadrax.



**SuperFly Datalink
White**

1000BASE-T Ethernet
10G Ethernet

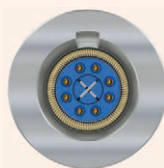

**SuperFly Datalink
Blue**

USB 2.0
SuperSpeed USB 3.0

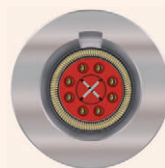

**SuperFly Datalink
Red**

eSATA / SATA
DVI-D (single)
HDMI • DisplayPort

- Ultra-small size
- Shielded Octaxial contacts
- Up to 5 Gbps
- 10Gb Ethernet and SuperSpeed USB
- New Red insert for high-speed video, consult factory for layouts
- Environmentally protected
- Factory-terminated cables or discrete contacts and cables for customer assembly

The high-speed nano miniature connector for harsh environments

CONNECTOR CONFIGURATIONS

Quick -disconnect “push-pull” versions are ideal for tactical gear. Threaded-coupling versions are intended for aircraft and space-grade applications where secure mating is a requirement.



Quick Disconnect



Threaded Coupling



Straight PC Tails

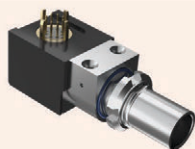

Right Angle PC Tails

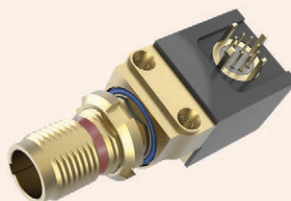

Conformal-coating-compliant panel mount connectors

Push-Pull Quick-Disconnect

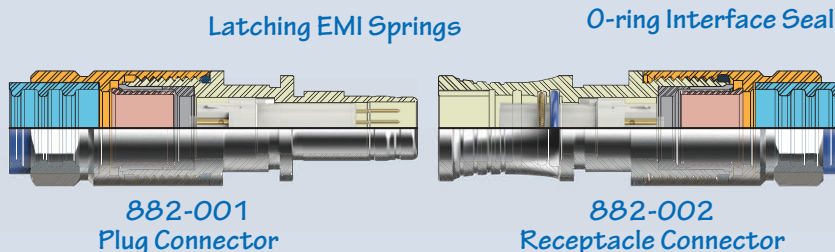

Push-pull SuperFly Datalink receptacle connectors feature two canted coil springs for secure mating and excellent EMI protection. A fluorosilicone O-ring provides watertight sealing when mated.

Cable Connector



E1 Ochito®

Cable connectors feature gold-plated crimp contacts, precision insulators, integral backshell, sealing grommet and machined shells.

Selection Guide: SuperFly Datalink White for Ethernet



SuperFly Datalink Connectors, Octaxial, White

White dielectric indicates 100 ohm differential impedance for Ethernet protocols. Ideal for 1000BASE-T and 10GBASE-T applications in hostile environments with temperature extremes, high vibration, electromagnetic interference, as well as moisture exposure. Compatible with SAE AS6070 200°C flight-grade cable. Accepts 24 AWG or 26 AWG wire sizes. Available with secure threaded coupling or push-pull mating.

Quick Disconnect for 10Gb Ethernet



882-001 Cable Plug

Integral backshell and cable grommet. Supplied as unassembled kit for termination to Cat 6A Ethernet cable.



882-002 Cable Receptacle

Integral backshell and cable grommet. Supplied as unassembled kit for termination to Cat 6A Ethernet cable. Mates to 881-001.



882-005 Panel Receptacle, PCB

Rear panel jam nut mount receptacle has O-ring seals and epoxy potting for watertight sealing. Mates with 882-001.



882-008 Panel Receptacle, 90° PCB

Rear panel jam nut mount receptacle has O-ring seals and epoxy potting for watertight sealing. Mates with 882-001.



8571-0007 Cordset, Single-Ended

Pre-wired with aerospace-grade CAT 6A Ethernet cable. Cable has plug or receptacle on one end, other end is unterminated.



8571-0008 Cordset, Double-Ended

Pre-wired with aerospace-grade CAT 6A Ethernet cable. Cable has plug on one end and receptacle on the other end.



8571-0009 RJ45 Patchcord, Ground

Pre-wired with commercial-grade CAT 6A Ethernet cable. Cable has RJ45 plug on one end and plug or receptacle on the other end.



8571-0010 RJ45 Patchcord, Flight

Pre-wired with flight-grade CAT 6A Ethernet cable. Cable has RJ45 plug on one end and plug or receptacle on the other end.

Threaded Coupling for 10Gb Ethernet



882-003 Cable Plug

Integral backshell and cable grommet. Supplied as unassembled kit for termination to Cat 6A Ethernet cable.



882-006 Cable Receptacle

Integral backshell and cable grommet. Supplied as unassembled kit for termination to Cat 6A Ethernet cable. Mates with 882-003.



882-004 Panel Receptacle, PCB

Rear panel jam nut mount receptacle has O-ring seals and epoxy potting for watertight sealing. Mates with 882-003.



882-007 Panel Receptacle, 90° PCB

Rear panel jam nut mount receptacle has O-ring seals and epoxy potting for watertight sealing. Mates with 882-003.



8571-0012 Cordset, Single-Ended

Pre-wired with aerospace-grade CAT 6A Ethernet cable. Cable has plug or receptacle on one end, other end is unterminated.



8571-0013 Cordset, Double-Ended

Pre-wired with aerospace-grade CAT 6A Ethernet cable. Cable has plug on one end and receptacle on the other end.



8571-0015 RJ45 Patchcord, Ground

Pre-wired with commercial-grade CAT 6A Ethernet cable. Cable has RJ45 plug on one end and plug or receptacle on the other end.



8571-0016 RJ45 Patchcord, Flight

Pre-wired with flight-grade CAT 6A Ethernet cable. Cable has RJ45 plug on one end and plug or receptacle on the other end.

Flight-Grade 100 Ohm Ethernet Cable



963-033 S/FTP Cable

24 and 26 AWG. S/FTP construction, foil shielded data pairs. High performance shielded cable is AS6070/5 and /6 approved.



963-003 and 963-037 S/UTP Cable

24 and 26 AWG. S/UTP construction with fluoropolymer spline. Meets FAA flammability requirements.

Selection Guide: SuperFly Datalink Blue for USB 3.0

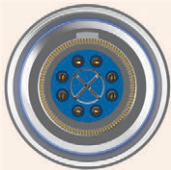

SuperFly Datalink Connectors, Octaxial, Blue

Blue dielectric indicates 90 ohm differential impedance for SuperSpeed USB. Ideal for USB 3.0 applications in hostile environments with temperature extremes, vibration, electromagnetic interference and moisture exposure. Designed for use with high performance aerospace grade USB 3.0 cable. Available with threaded coupling or push-pull mating.

Quick Disconnect for USB 3.0

882-009 Cable Plug

Integral backshell and cable grommet. Supplied as unassembled kit for termination to USB 3.0 cable.



882-010 Cable Receptacle

Integral backshell and cable grommet. Supplied as unassembled kit for termination to USB 3.0 cable. Mates to 881-009.



882-013 Panel Receptacle, PCB

Rear panel jam nut mount receptacle has O-ring seals and epoxy potting for watertight sealing. Mates with 882-009.



882-016 Panel Receptacle, 90° PCB

Rear panel jam nut mount receptacle has O-ring seals and epoxy potting for watertight sealing. Mates with 882-009.



8572-0006 Cordset, Single-Ended

Pre-wired with aerospace-grade or commercial-grade USB 3.0 cable. Cable has plug or receptacle on one end, other end is unterminated.



8572-0007 Cordset, Double-Ended

Pre-wired with aerospace-grade or commercial-grade USB 3.0 cable. Cable has plug on one end and receptacle on the other end.



8572-0008 Patchcord, USB

Pre-wired with commercial-grade USB 3.0 cable. Cable has standard USB connector on one end, other end is SuperFly Datalink.



Threaded Coupling for USB 3.0

882-011 Cable Plug

Integral backshell and cable grommet. Supplied as unassembled kit for termination to USB 3.0 cable.



882-014 Cable Receptacle

Integral backshell and cable grommet. Supplied as unassembled kit for termination to USB 3.0 cable. Mates with 882-011.



882-012 Panel Receptacle, PCB

Rear panel jam nut mount receptacle has O-ring seals and epoxy potting for watertight sealing. Mates with 882-011.



882-015 Panel Receptacle, 90° PCB

Rear panel jam nut mount receptacle has O-ring seals and epoxy potting for watertight sealing. Mates with 882-011.



8572-0010 Cordset, Single-Ended

Pre-wired with aerospace-grade or commercial-grade USB 3.0 cable. Cable has plug or receptacle on one end, other end is unterminated.



8572-0011 Cordset, Double-Ended

Pre-wired with aerospace-grade or commercial-grade USB 3.0 cable. Cable has plug on one end and receptacle on the other end.



8572-0013 Patchcord, USB

Pre-wired with commercial-grade USB 3.0 cable. Cable has standard USB connector on one end, other end is SuperFly Datalink.



90 Ohm USB 3.0 Cable

963-110 Flight-Grade Cable

High temperature, high performance, fluoropolymer materials, shielded. High speed pairs have braid shields. -65° to +200°C.



963-118 Commercial-Grade Cable

Black PVC jacket, foamed PE wire insulation. High speed pairs have foil shields. 0 to +80°C.



HIGH-SPEED
RACK-AND-PANEL
CONNECTOR
WITH EL OCHITO®
OCTAXIAL CONTACTS



The next-generation micro miniature rectangular connector with El Ochito contacts for high-speed aerospace applications



The Series 792 connector brings high-speed data-rate performance to the Glenair Series 79 rectangular family. Size 8 cavities accept standard Quadrax or El Ochito® shielded octaxial contacts making it a perfect choice for radars, weapons systems, mission computers and displays, communications gear, and more.

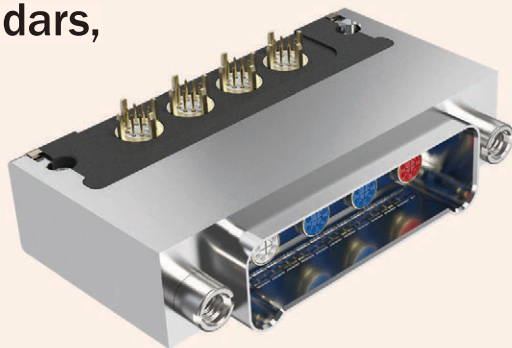

El Ochito®

- High-speed Ethernet, USB 3.0, HDMI, and DisplayPort
- PCB-mount and cable connectors
- Scoop-proof interface
- 12 arrangements and 6 shell sizes
- Precision-machined dual-lobe polarized shells
- Environmentally sealed
- Integrated EMI shielding and grounding
- Blind mating

The next-generation micro miniature rectangular for high-speed aerospace applications

DESCRIPTION	REQUIREMENT	PROCEDURE / NOTES
Operating temperature	-65° to +175°C	EIA-364-32 Test Condition IV
Current rating	1.5 Amps (datalink contacts) 5 Amps (Size #23 contacts)	Datalink contacts tested: El Ochito® White
DWV (sea level)	750 VAC (Size #23 contacts) 1000 VAC (datalink contacts)	EIA-364-20
Insulation resistance	5000 MΩ minimum	EIA-364-21
Contact resistance, 25°C	55 millivolt maximum	EIA-364-06, 1.0 A test current, #24 AWG wire

DESCRIPTION	REQUIREMENT	PROCEDURE / NOTES	
Shell-to-shell resistance	2.5 millivolt maximum	EIA-364-83	
Shielding effectiveness	Frequency	Attenuation dB	EIA-364-66
	100	75	
	1000	50	
	3000	44	
	6000	38	
10000	35		
Ingress protection	IP67 rating	IEC-60529	

Insert Arrangements

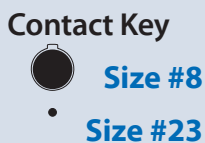
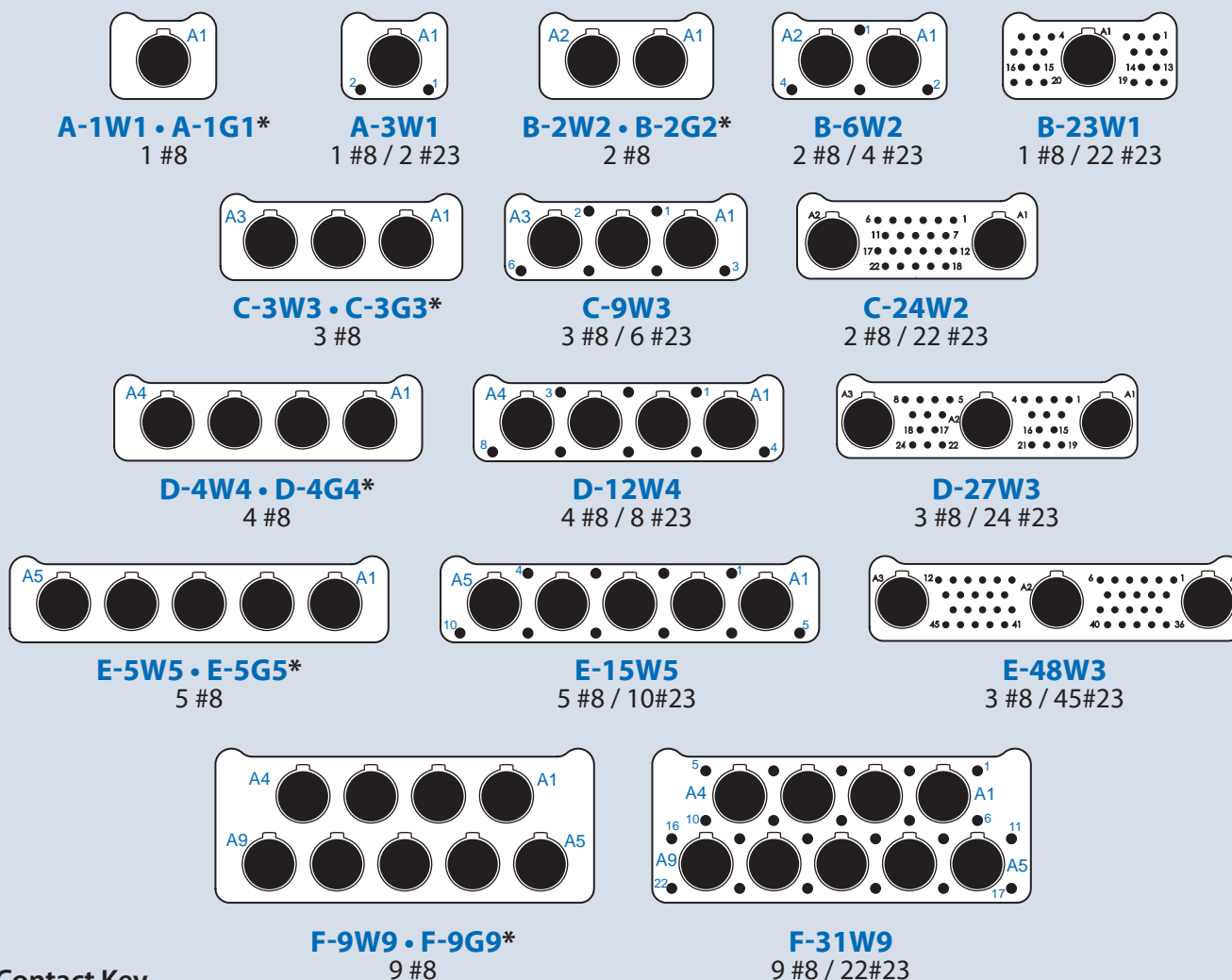

* Grounded aluminum insert

HIGH-SPEED Series 792

The next-generation micro miniature rectangular for high-speed / high-data rate aerospace applications



Save Size and Weight with Series 792 Connectors

The Multi-Port Multi-Protocol Connector with El Ochito® Contacts

About The Series 792

The Series 792 brings high-speed board-to-wire capability to the Glenair Series 79 family of ultraminiature rectangular connectors. The Series 792 is intended for avionics and aerospace equipment exposed to high-vibration and hostile environments.

The 792 supports quadrx contacts for ARINC 664 and El Ochito® octaxial contacts for 10Gb Ethernet, USB 3.0, HDMI and other protocols.

Machined aluminum alloy shells feature dual lobes for polarization. Pin contacts are recessed to prevent scooping damage. Crimp contacts conform to M39029 requirements and are rear release.

An optional ground spring in the receptacle minimizes EMI. Fluorosilicone face seals and wire grommets protect from moisture and contamination. Panel mount versions are available with an O-ring—or for improved panel bonding—a metal spring.

Board mount versions include straight or right angle terminals. Right angle PCB connectors feature an aluminum cover for added EMI protection.

Metal EMI Panel Spring

A gold-plated panel spring option is available for Series 792 connectors with panel mount flanges. This spring provides improved electrical bonding.



Twinax, Quadrx and El Ochito® Connectors are available in three configurations: twinax for a single high-speed wire pair, quadrx for two data pairs, and El Ochito® for four data pairs.



PCB Connectors

Series 792 PCB connectors have straight or right angle PC tails. Contacts are non-removable and are epoxy sealed. Right-angle connectors eliminate the need for board-to-panel I/O jumpers.



El Ochito®
White
GbE
10GbE



El Ochito®
Blue
USB 3.0



El Ochito®
Red
HDMI, SATA,
DisplayPort

El Ochito® Contacts

Series 792 connectors feature El Ochito® octaxial contacts for Ethernet, SuperSpeed USB, HDMI, DisplayPort, SATA and other multi-gigabit protocols. Multiple protocols can be supported in a single multi-port connector.

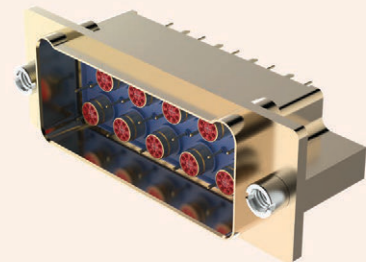

Up to 9 data ports

The Series 792 Size F with nine ports is the largest connector in the series and is the only two row version. Sizes A – E, with one to five ports, are single row.



Panel Mount

Panel mount connectors have an O-ring and threaded mounting holes for easy installation. Suitable for blind mate modules, the Series 792 is available with guide pins and float mounts.



Cable Connectors

Quadrx and El Ochito® contacts snap into Series 792 cable connectors and are easily removed with a standard plastic tool. Alignment keys provide correct orientation.

HIGH-SPEED Series 792



The next-generation micro miniature rectangular for high-speed / high-data rate aerospace applications

Cable Connectors Snap-in crimp contacts		Panel Mount Connectors Snap-in crimp contacts		Float Mount Connectors Snap-in crimp contacts	
Plug	Receptacle	Plug	Receptacle	Plug	Receptacle
792-001	792-002	792-003	792-004	792-013	792-014

El Ochito® Printed Circuit Board Connectors with Octaxial Contacts
Epoxy-sealed non-removable PCB terminals

Straight PCB		Panel Mt Straight PCB		90° PCB		Panel Mount 90° PCB	
Plug	Receptacle	Plug	Receptacle	Plug	Receptacle	Plug	Receptacle
792-005	792-006	792-007	792-008	792-009	792-010	792-011	792-012

Quadrax Printed Circuit Board Connectors
Epoxy-sealed non-removable PCB terminals

Straight PCB		Panel Mt Straight PCB		90° PCB		Panel Mount 90° PCB	
Plug	Receptacle	Plug	Receptacle	Plug	Receptacle	Plug	Receptacle
792-018	792-019	792-020	792-021	792-022	792-023	792-024	792-025

Series 792 High-speed Ultraminiature Rectangular Connectors with El Ochito® Octaxial Contacts

El Ochito®
White
GbE
10GbE

El Ochito®
Blue
USB 3.0

El Ochito®
Red
HDMI, SATA,
DisplayPort

- 10GbE, SuperSpeed USB, and multi-gigabit shielded pairs
- Crimp shield termination and threaded contact types
- Snap-in, rear release
- Environmentally protected
- Aerospace-grade performance

RECOMMENDED BACKSHELL

799-164
Split EMI Banding Backshell

NEXT-GENERATION
HIGH-SPEED
MICRO
MINIATURE
CONNECTORS

SERIES
806
MIL-AERO

806 Mil-Aero: Advanced
Performance, Reduced
Size and Weight
Connector Series IAW
MIL-DTL-38999



Series 806 meets key performance benchmarks for harsh vibration, shock, and environmental settings—as well as high-altitude, unpressurized aircraft zones with aggressive voltage ratings and altitude immersion standards.



Series 806 with four 10GbE El Ochito channels

El Ochito®

- Next-generation micro miniature aerospace-grade circular connector
- Upgraded environmental, electrical and mechanical performance IAW MIL-DTL-38999 Series III
- Integrated anti-decoupling technology
- High-Speed El Ochito® and hybrid #22HD contact arrangements

SERIES 806 MIL-AERO CONNECTORS WITH EL OCHITO® CONTACTS



White
GbE
10GbE

Blue
USB 3.0

Red
HDMI, SATA,
DisplayPort

- 10GbE, SuperSpeed USB 3.0, HDMI and DisplayPort
- Crimp shield termination and threaded contact types
- Snap-in, rear release
- Environmentally protected

HIGH-SPEED Series 806 Mil-Aero Micro Miniature Circular Connectors with El Ochito® octaxial contacts



Series 806 with El Ochito® contact arrangements

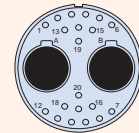
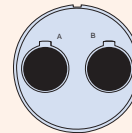
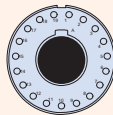
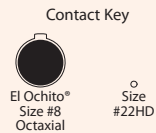

Insert Arrangement	10-1	14-20A		16-2	16-22	
No. of Contacts	1x #8	1x #8	19x #22HD	2x #8	2x #8	20x #22HD

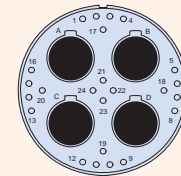
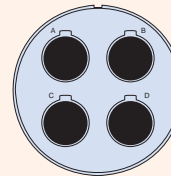
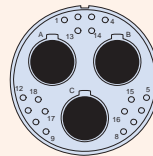
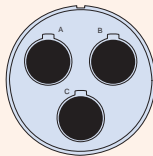
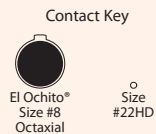

Insert Arrangement	18-3	18-21		20-4	20-28	
No. of Contacts	3x #8	3x #8	18x #22HD	4x #8	4x #8	24x #22HD

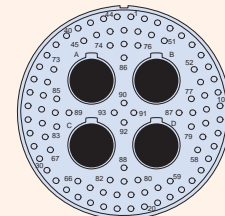
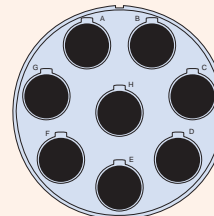
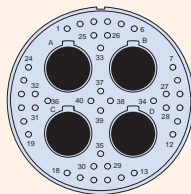
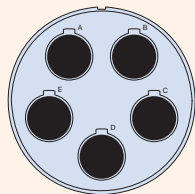
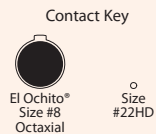

Insert Arrangement	22-5	22-44		24-8	24-97	
No. of Contacts	5x #8	4x #8	40x #22HD	8x #8	4x #8	93x #22HD

Polarizing Positions

Position	A°	B°	C°	D°
A	105	140	215	265
B	102	170	248	305
C	80	150	230	295
D	68	140	205	275
E	64	155	234	304
F	72	120	200	298

FEATURES

- Triple-start stub ACME mating thread
- El Ochito® Octaxial and hybrid High density #22HD arrangements for reduced size / weight and high-speed performance
- Aerospace-grade materials, construction, and performance

CONNECTOR CONSTRUCTION

- Shell and coupling nut: aluminum or stainless steel
- Contacts: copper alloy, gold plating
- Wire grommet: fluorosilicone
- Dielectric inserts: high grade rigid dielectric
- Peripheral seal: fluorosilicone
- Ground spring: copper alloy, nickel plating
- Contact retention clips: copper alloy
- Ratchet springs: stainless steel, passivated
- Retainer rings: stainless steel, passivated
- Clinch nuts: stainless steel, passivated

RECOMMENDED BACKSHELL

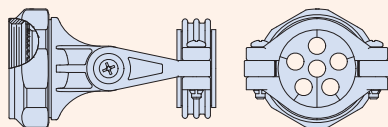

627-261

Swing-Arm 3-in-1 strain relief
with cable bushing (consult factory)

HIGH-SPEED Series 806 Mil-Aero Micro Miniature Circular Connectors

with El Ochito® octaxial contacts

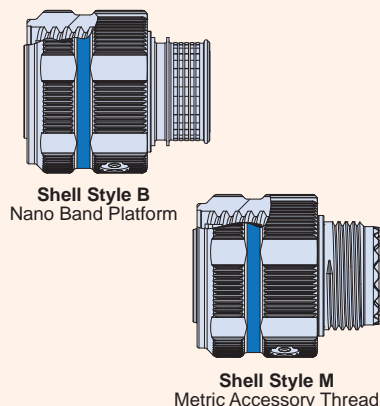

How To Order Series 806 El Ochito® Plugs						
SAMPLE PART NUMBER	806-012	-ME	18-3	S	M	A
Product	806-012 = Cable Plug					
Shell Material and Finish	ME = Aluminum, Electroless Nickel MT = Aluminum, Ni/PTFE ZR = Aluminum, Black Zinc-Nickel NF = Aluminum, Olive Drab Cadmium Z1 = Stainless Steel, Passivated					
Arrangement Number (Shell Size - Insert Arr.)	See Contact Arrangements Table					
Contact Type	P = Pin S = Socket					
Shell Style	M = Metric accessory threads B = Nano Band platform					
Polarizing Position	A B C D E F					

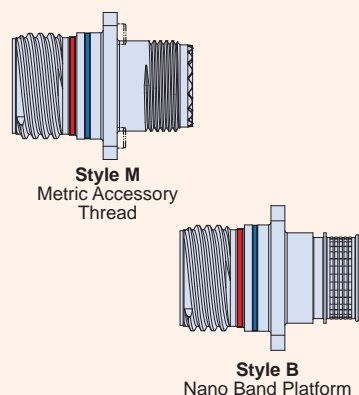

How To Order Series 806 El Ochito® Square Flange Receptacles							
SAMPLE PART NUMBER	806-013	-MT	18-21	P	B	C	A
Product	806-013 = Panel Receptacle, Square Flange, Crimp						
Shell Material and Finish	ME = Aluminum, Electroless Nickel MT = Aluminum, Ni/PTFE ZR = Aluminum, Black Zinc-Nickel NF = Aluminum, Olive Drab Cadmium Z1 = Stainless Steel, Passivated						
Arrangement Number (Shell Size - Insert Arr.)	See Contact Arrangements Table						
Contact Type	P = Pin S = Socket						
Shell Style	M = Metric accessory threads B = Nano Band platform						
Mounting Hole Style	T = Thru holes C = Clinch nut, #4-40 (rear panel mounting)						
Polarizing Position	A B C D E F						

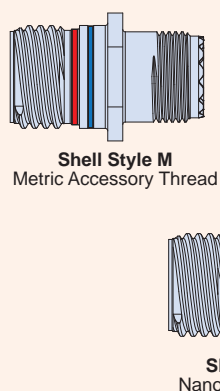

How To Order Series 806 El Ochito® In-Line Receptacles						
SAMPLE PART NUMBER	806-019	-MT	18-21	P	B	A
Product	806-019 = In-Line Receptacle					
Shell Material and Finish	ME = Aluminum, Electroless Nickel MT = Aluminum, Ni/PTFE ZR = Aluminum, Black Zinc-Nickel NF = Aluminum, Olive Drab Cadmium Z1 = Stainless Steel, Passivated					
Arrangement Number (Shell Size - Insert Arr.)	See Contact Arrangements Table					
Contact Type	P = Pin S = Socket					
Shell Style	M = Metric accessory threads B = Nano Band platform					
Polarizing Position	A B C D E F					

HIGH-SPEED Series 806 Mil-Aero Micro Miniature Circular Connectors with El Ochito® octaxial contacts

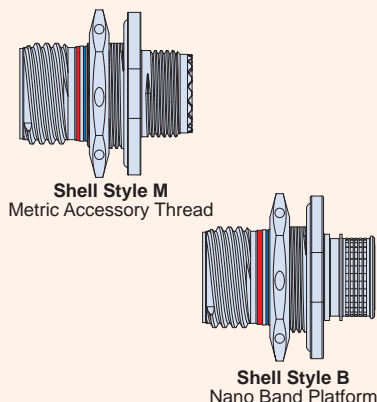

How To Order Series 806 El Ochito® Jam Nut Receptacles						
SAMPLE PART NUMBER	806-020	-MT	18-21	P	B	A
Product	806-020 = Jam Nut Receptacle					
Shell Material and Finish	ME = Aluminum, Electroless Nickel MT = Aluminum, Ni/PTFE ZR = Aluminum, Black Zinc-Nickel NF = Aluminum, Olive Drab Cadmium Z1 = Stainless Steel, Passivated					
Arrangement Number (Shell Size - Insert Arr.)	See Contact Arrangements Table					
Contact Type	P = Pin S = Socket					
Shell Style	M = Metric accessory threads B = Nano Band platform					
Polarizing Position	A B C D E F					

Table VI - Ochito Contact Positions

B = Blue, R = Red, W = White

SYM	El Ochito Contact Designator							
	A	B	C	D	E	F	G	H
E	W	W	W	W	W	W	W	W
E2	B	W	W	W	W	W	W	W
E3	R	W	W	W	W	W	W	W
E4	B	B	W	W	W	W	W	W
E5	R	B	W	W	W	W	W	W
E6	R	R	W	W	W	W	W	W
E7	B	B	B	W	W	W	W	W
E8	R	B	B	W	W	W	W	W
E9	R	R	B	W	W	W	W	W
E10	R	R	R	W	W	W	W	W
E11	B	B	B	B	W	W	W	W
E12	R	B	B	B	W	W	W	W
E13	R	R	B	B	W	W	W	W
E14	R	R	R	B	W	W	W	W
E15	R	R	R	R	W	W	W	W
E16	B	B	B	B	B	W	W	W
E17	R	B	B	B	B	W	W	W
E18	R	R	B	B	B	W	W	W
E19	R	R	R	B	B	W	W	W
E20	R	R	R	R	B	W	W	W
E21	R	R	R	R	R	W	W	W
E22	B	B	B	B	B	B	W	W
E23	R	B	B	B	B	B	W	W
E24	R	R	B	B	B	B	W	W
E25	R	R	R	B	B	B	W	W
E26	R	R	R	R	B	B	W	W
E27	R	R	R	R	R	B	W	W
E28	R	R	R	R	R	R	W	W
E29	B	B	B	B	B	B	B	W
E30	R	B	B	B	B	B	B	W
E31	R	R	B	B	B	B	B	W
E32	R	R	R	B	B	B	B	W
E33	R	R	R	R	B	B	B	W
E34	R	R	R	R	R	B	B	W
E35	R	R	R	R	R	R	B	W
E36	R	R	R	R	R	R	R	W
E37	B	B	B	B	B	B	B	B
E38	R	B	B	B	B	B	B	B
E39	R	R	B	B	B	B	B	B
E40	R	R	R	B	B	B	B	B
E41	R	R	R	R	B	B	B	B
E42	R	R	R	R	R	B	B	B
E43	R	R	R	R	R	R	B	B
E44	R	R	R	R	R	R	R	B
E45	R	R	R	R	R	R	R	R

How To Order Series 806 El Ochito® PCB Receptacles								
SAMPLE PART NUMBER	806-039	-MT	14	E	-	20A	P	A
Product	806-039 = Jam Nut 806-040 = Square-Flange							
Shell Material and Finish	ME = Aluminum, Electroless Nickel MT = Aluminum, Ni/PTFE ZR = Aluminum, Black Zinc-Nickel NF = Aluminum, Olive Drab Cadmium Z1 = Stainless Steel, Passivated							
Shell Size	10, 14, 16, 18, 20, 22, 24							
Contact Type	See Table VI							
Ground Option	G = Common Ground - = None							
Contact Arrangement Number	See Contact Arrangements Table							
Contact Gender	P = Pin S = Socket							
Panel Mount Thru-Hole Style	(for 806-040 square-flange only) T = Thru-Hole C = Clinch Nuts for Rear Panel Mount Omit for 806-039 Jam Nut							
Polarizing Position	A B C D E F							

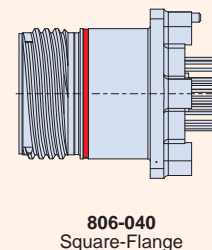
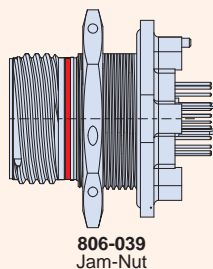

ADVANCED -
PERFORMANCE
MIL-AERO
CONNECTORS



“Better than QPL” MIL-DTL-38999
High-Speed Solution



SuperNine® high-speed connectors with special inserts to accommodate El Ochito® octaxial contacts

- **Tooled and ready-to-ship high-speed and hybrid insert arrangement connectors for size #8 El Ochito shielded contacts. Arrangements for #8, #12, and #16 Coax, Twinax, and Quadrax also available**
- **Supported applications: 10/100/1G/10G BASE-T Ethernet, HDMI, DisplayPort, SATA, USB 3.0, 1553 databus and general RF or differential data transmission**

El
Ochito®



Crimp contact
and PC tail
configurations

EL OCHITO CONTACT REFERENCE GUIDE

Contact Type	White, Type I	White, Type II	Blue, Type I	Red, Type I
Pin	858-003	858-005	858-028	858-030-01
Socket	858-004	858-006	858-029	858-031

RECOMMENDED BACKSHELL

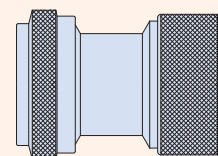

377HS121

Series 37 Aluminum Backshell for
SuperNine plug and receptacle
connectors. Straight, 45°, and 90°
configurations available.

“BETTER THAN QPL”

High-Speed SuperNine® MIL-DTL-38999



with El Ochito® octaxial contacts

How To Order SuperNine® High-Speed Connectors with El Ochito contacts											
Sample Part Number	233-217					-G6	NF	25	-	08	A N 909XX
Series / Basic Part No.	233-217 with Accessory Thread 233-224 Integral Banding Porch										
Connector Style	G6 Plug, EMI spring 05 in-line receptacle 07 jam-nut recept. 00 wall mt. recept., slotted holes CM wall mt. recept., metric clinch nuts CS wall mt. recept., std. clinch nuts DO wall mt. recept., thru holes HM wall mt. recept., metric helicoils HS wall mt. recept., std. helicoils										
Material/Finish	NF = Cad/O.D. ME = Electroless Nickel MT = Nickel PTFE ZR = Black Zinc Nickel										
Shell Size	9, 11, 13, 17, 19, 21, 23, 25										
Ground Option	G = Common Ground - = None										
Insert Arrangement	See insert arrangement tables, next pages										
Insert Designator	A = Pin insert, less contacts B = Socket insert, less contacts										
Alternate Polarization*	A, B, C, D, E, N = Normal (IAW MIL-DTL-38999 Series III)										
Optional Mod Code	909XX = Supplies connector with contacts										

How To Order SuperNine® High-Speed Quick-Disconnect Connectors with El Ochito contacts											
Sample Part Number	233-260					-G6	ME	25	-	8	E A N -909EP
Series / Basic Part No.	233-260 High-Speed Quick Disconnect										
Connector Style	G6 = Quick Disconnect Plug										
Material/Finish	NF = Cad/O.D. ME = Electroless Nickel MT = Nickel PTFE ZR = Black Zinc Nickel Z1 = SST, Passivated										
Shell Size	9, 11, 17, 19, 21, 23, 25										
Ground Option	G = Common Ground - = None; See Note 8										
Insert Arrangement	See insert arrangement tables, next pages										
Lanyard Length Code	consult factory or SuperNine catalog										
Contact Style	A = Pin Less Contact B = Socket Less Contact										
Alternate Polarization*	A, B, C, D, E, N = Normal (IAW MIL-DTL-38999 Series III)										
Optional Mod Code	909ES = Connector with El Ochito Socket contacts 909EP Connector with El Ochito Pin contacts										

How To Order SuperNine® High-Speed PC-Tail Threaded Standoff Receptacles with El Ochito contacts											
Sample Part Number	233-218					-00	M	17	E	-	02 S N
Series / Basic Part No.	High-Speed PC tail wall mount receptacles, threaded standoffs										
Connector Style	07 jam-nut 00 wall-mount, slotted holes CM wall mt., metric clinch nuts CS wall mt., std. clinch nuts HM wall mt., metric helicoils HS wall mt., std. helicoils										
Material/Finish	NF = Cad/O.D. ME = Electroless Nickel MT = Nickel PTFE ZR = Black Zinc Nickel										
Shell Size	9, 11, 13, 15, 17, 19, 21, 23, 25										
Contact Type	E = El Ochito ⁷										
Ground Option	G = Common Ground - = None										
Insert Arrangement	See insert arrangement tables, next pages										
Contact Style	P = Pin, PC Tail S = Socket, PC Tail										
Alternate Polarization*	A, B, C, D, E, N = Normal (IAW MIL-DTL-38999 Series III)										

How To Order SuperNine® High-Speed Wall Mount Receptacles with El Ochito contacts											
Sample Part Number	233-225					-00	ME	17	E	-	02 S N
Series / Basic Part	SuperNine® High-Speed, dual flange wall-mount receptacle										
Connector Style*	07 jam-nut 00 wall-mount, slotted holes/stand off, std. threads 10 Wall-mount, slotted holes/stand off, metric threads CM wall-mount, metric clinch nuts CS wall mount, std. clinch nuts HM wall mount, metric helicoils HS wall mount, std. helicoils										
Material/Finish	NF = Cad/O.D. ME = Electroless Nickel MT = Nickel PTFE ZR = Black Zinc Nickel										
Shell Size	9, 11, 13, 17, 19, 21, 23, 25										
Contact Type	E = El Ochito										
Ground Option	G = Common Ground - = None										
Insert Arrangement	Per MIL-STD-1560, see page C-5 and C-6										
Contact Style	P = Pin, PC Tail S = Socket, PC Tail										
Alternate Polarization*	A, B, C, D, E, N = Normal (IAW MIL-DTL-38999 Series III)										

High-speed size #8 and hybrid insert arrangements (note: size #8 cavities keyed for contact polarization)

Contact Legend

- #23 ● #22D ◦
- #16 ⊕ #20 ⊖
- #12 ◐ #8 ◑



Insert Arrangement	9G5*	11-1	13-14	17-2
No. of Contacts	1x #8	1x #8	1x #8 14x #23	1x #8 38x #22D

*Only available with ground plane option

Contact Legend

- #23 ● #22D ◦
- #16 ⊕ #20 ⊖
- #12 ◐ #8 ◑

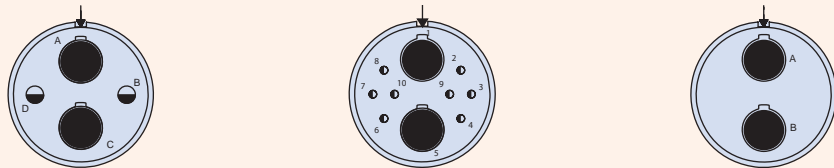

Insert Arrangement	17-22	17-60	17-75
No. of Contacts	2x #8 2x #12	2x #8 8x #22	2x #8

Contact Legend

- #23 ● #22D ◦
- #16 ⊕ #20 ⊖
- #12 ◐ #8 ◑

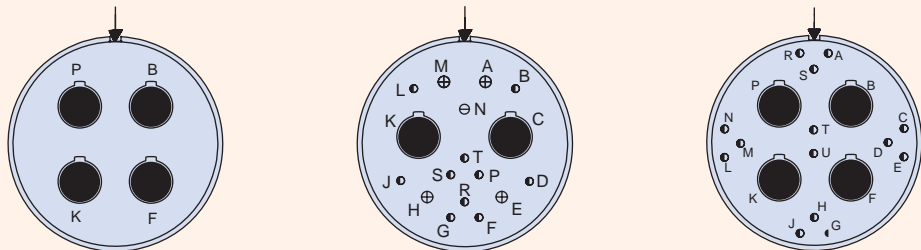

Insert Arrangement	19-4	19-17	19-18
No. of Contacts	4x #8	2x #8 4x #16 1x #20 10x #22D	4x #8 14x #22D

Contact Legend

- #23 ● #22D ◦
- #16 ⊕ #20 ⊖
- #12 ◐ #8 ◑

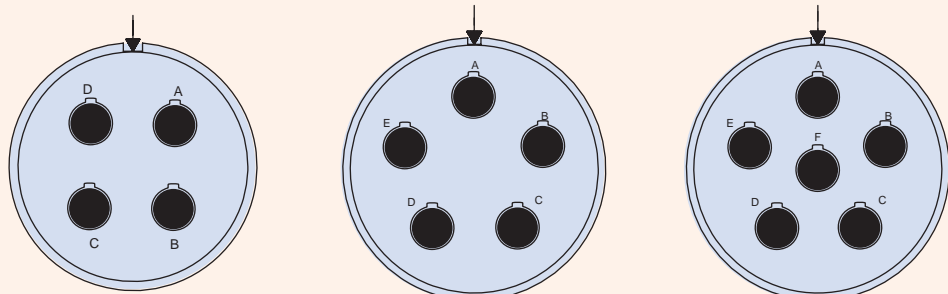

Insert Arrangement	21-75	23-5	23-6
No. of Contacts and Size	4x #8	5x #8	6x #8

SuperNine® High-speed connectors



High-speed size #8 and hybrid insert arrangements
(note: size #8 cavities keyed for contact polarization)

Contact Legend
 #23 ● #22D ◉
 #16 ⊕ #20 ⊖
 #12 ◐ #8 ◑

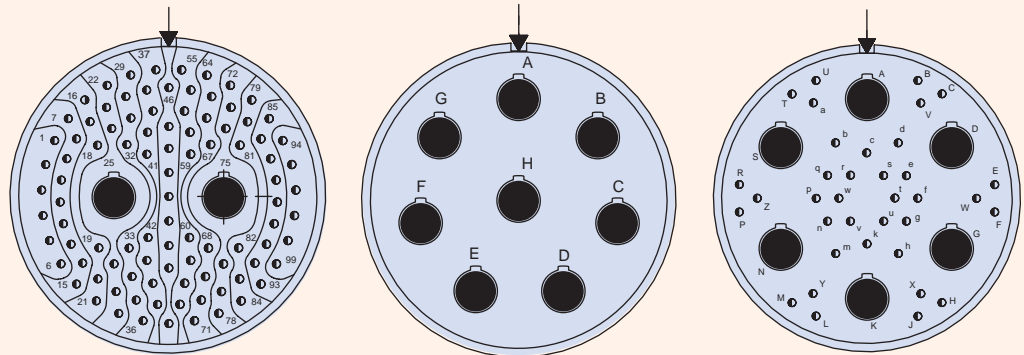

Insert Arrangement	25-7		25-8	25-17	
No. of Contacts and Size	2x #8	97x #22	8x #8	6x #8	36x #22

Contact Legend
 #23 ● #22D ◉
 #16 ⊕ #20 ⊖
 #12 ◐ #8 ◑

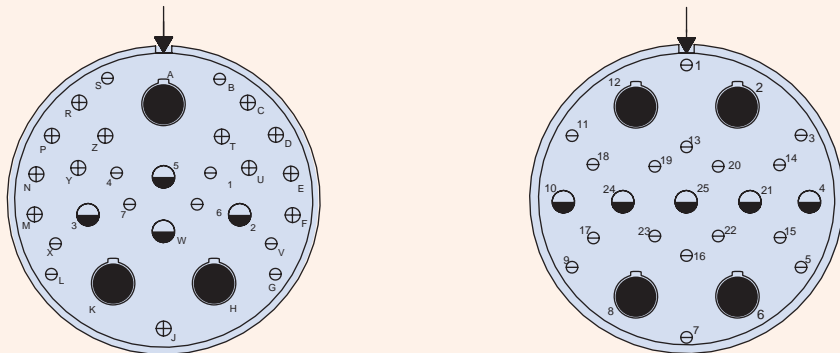

Insert Arrangement	25-20				25-26		
No. of Contacts and Size	3x #8	4x #12	13x #16	10x #20	4x #8	5x #12	16x #20

Contact Legend
 #23 ● #22D ◉
 #16 ⊕ #20 ⊖
 #12 ◐ #8 ◑

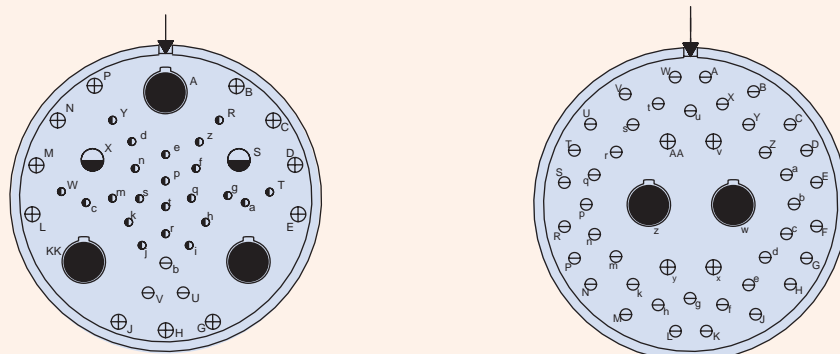

Insert Arrangement	25-41					25-46		
No. of Contacts and Size	3x #8	2x #12	11x #16	3x #20	22x #22D	2x #8	4x #16	40x #20

10G HIGH-SPEED
CONTACT MODULES
FOR GLENAIR
SIGNATURE SERIES
CONNECTORS



SPEEDMASTER™
High-speed 10G connection system for
Glenair SuperNine, Mighty Mouse, and
HiPer-D connectors

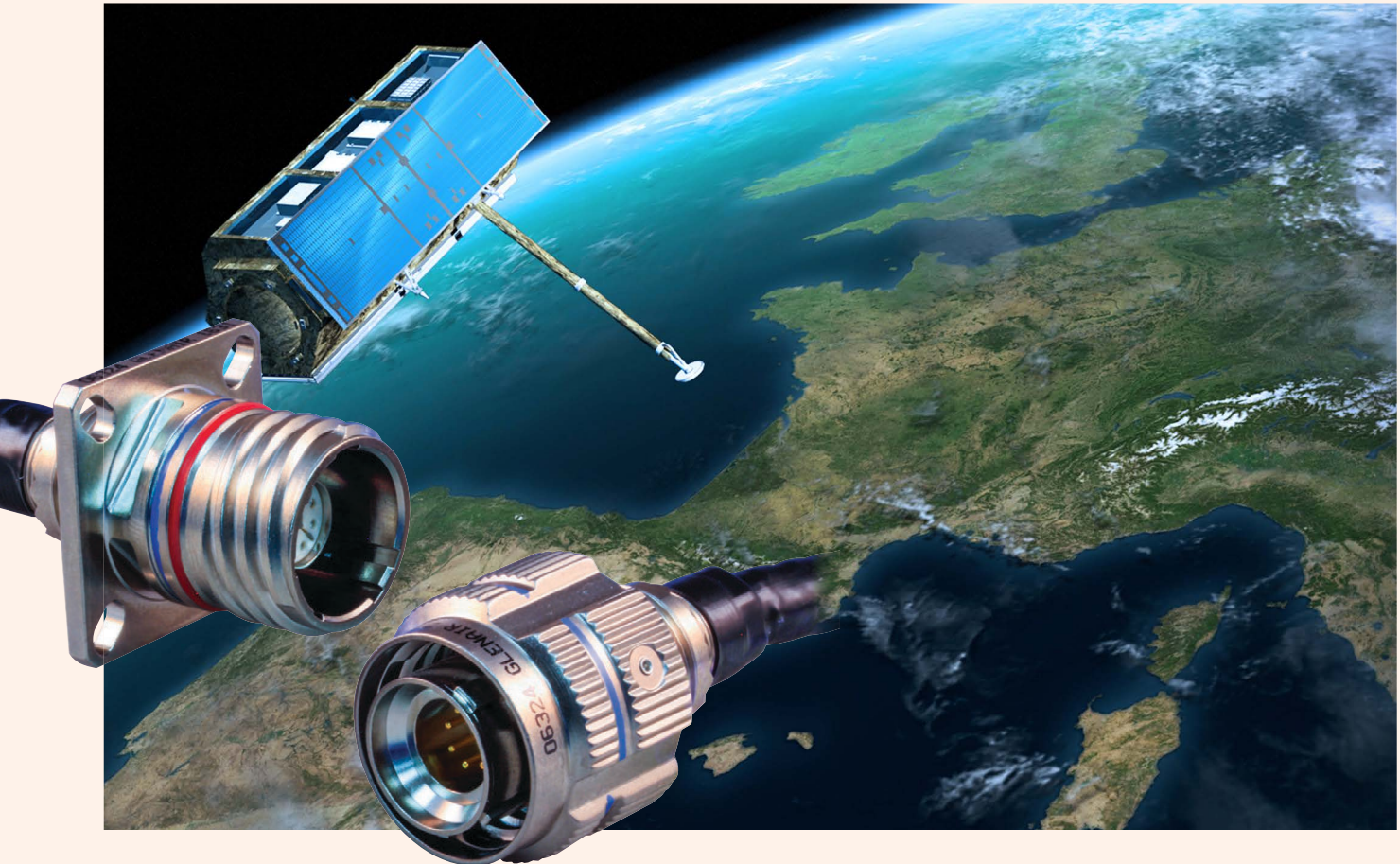

SpeedMaster™ is a dedicated size #22D crimp-contact module and insert package for SuperNine®, Mighty Mouse, and HiPer-D connectors. Optimized for high-speed Cat 6A Ethernet, the SpeedMaster™ 10G system offers industry-leading NEXT, return loss and insertion loss performance

- Utilizes aerospace industry standard #22D contacts, tools, and widely available Ethernet flight cable
- Significant weight reduction compared to Quadrax solutions (reduces cable requirement by half)



SpeedMaster Mighty Mouse
Locking Push/Pull Connectors



SpeedMaster HiPer-D Rectangular
(M24308 intermountable)



SpeedMaster SuperNine
"better than QPL" connectors

SpeedMaster™ High-Speed 10G Connection System



for Glenair SuperNine, Mighty Mouse, and HiPer-D connectors

SPEEDMASTER 10G NEXT-GENERATION HIGH-SPEED CONNECTION SYSTEM

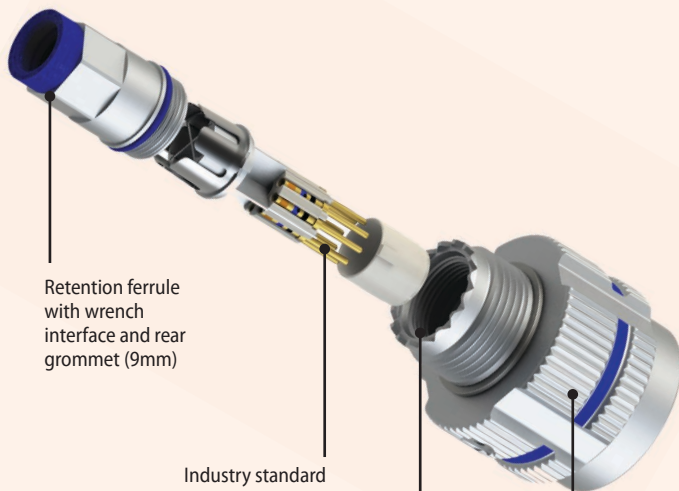

Retention ferrule with wrench interface and rear grommet (9mm)

Industry standard size #22D contacts

Genderless cavities allow for plug or receptacle connectors with pin or socket interface each with 8 contacts per module

Proven performance from circular and rectangular shell styles



SpeedMaster 10G modular inserts are available for Series 23 SuperNine – 38999, Series 80 Mighty Mouse – Locking Push / Pull and Series 28 HiPer-D – M24308 rectangular D-Sub connectors

The SpeedMaster Difference

SpeedMaster, the high-speed multi-contact solution for the Mighty Mouse, HiPer-D and SuperNine 38999 type family of connectors. Each SpeedMaster module consists of 4 pairs of pins or sockets incorporating industry standard size 22D contacts to provide 10G performance. Each module is individually shielded within the shell, and retained in place with a threaded ferrule. Additionally, module cavities are genderless allowing pin or socket interface for plugs or receptacles. Glenair offers these SpeedMaster contacts in 3 connector packages, including our small form factor Mighty Mouse Series 824 Locking Push/Pull, HiPer-D (M24308) hi-performance rectangular D-Sub, and our 38999 type “better than QPL” connectors allowing you to adapt and fit your application needs. These features result in a two fold benefit. An easily removable and repairable, shielded high performance contact packaged within robust industry standard connectors, helping to reduce network downtime and providing a connectorized solution to improve the overall network function and performance. Meet the demand for the next generation Cat 6A networks with SpeedMaster, the next generation contact system from Glenair.



The SpeedMaster 10G is optimized for high-speed Ethernet performance and incorporates standard M39029 #22D contacts isolated for superior NEXT, return loss and insertion loss performance



SpeedMaster Glass-Sealed Hermetic: Fully qualified to MIL-DTL-38999 Series III environmental and mechanical specifications. 10⁻⁷ Helium leak rate. Outstanding high-speed performance. Bulkhead feed-thru shown.

SpeedMaster™ High-Speed Cable					
Cable P/N	Cabel Category	Cable Construction	Wire Gage	Cable Dia.	Assembly Instruction
963-003-24	Cat 6A	SF/UTP	24	.280	AI85082
963-003-26	Cat 6A	SF/UTP	26	.220	
963-037	Cat 6A	SF/UTP	24	.260	
963-033-24	CAT 6A	S/FTP	24	.260	
933-033-26	CAT 6A	S/FTP	26	.220	

HIGH-SPEED SpeedMaster™ Pre-wired 10G high-speed contacts

858-102 10GBase-T Cat 6A Contacts

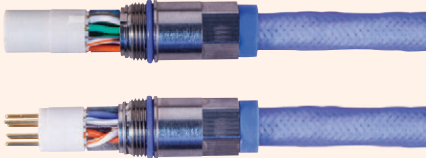

Pre-wired SpeedMaster assemblies are 100% tested and ready for use. Compatible with Glenair Series 80 Mighty Mouse, Series 28 HiPer-D or Series 23 SuperNine connectors with keyed size #8 cavities, these assemblies are available with three termination options: single-ended, SpeedMaster contacts on both ends, or with an RJ45 plug on one end. Contacts are wired per the guidelines of ARINC 664 Part 2 Appendix N.

Connector Compatibility

- Glenair 824-009 and -010 Mighty Mouse
- Glenair 280-098 thru -103 HiPer-D
- Glenair 233-219, 233-220 SuperNine

Contact Positions

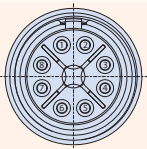

Mating Face of Pin Contacts

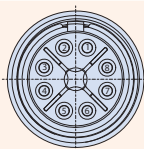

Mating Face of Socket Contacts

Part Number Development

Sample Part Number	8575-0001	-A	C	-1	-12
Product	8575-0001				
End A Contact Type	-A = 858-101 SpeedMaster pin -B = 858-100 SpeedMaster socket				
End B Contact/Connector	A = SpeedMaster pin B = SpeedMaster socket C = RJ45 plug N = No connector				
Cable Option	-1 = 963-003-24 -5 = 963-033-24 -2 = 963-003-26 -6 = 963-033-26 -4 = 963-037				
Length	Overall length in inches				

8575-0001 SPEEDMASTER™ WIRING DIAGRAMS

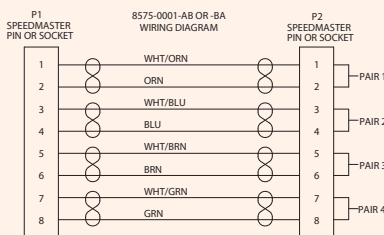

SPEEDMASTER TO SPEEDMASTER IS 1 TO 1.
MUST BE PIN TO SOCKET OR SOCKET TO PIN
CMT P2 FOR 8575-0001-AN OR -BN

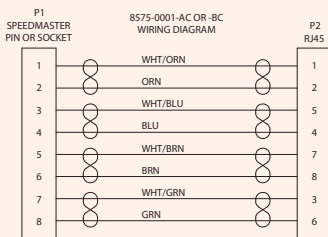

SPEEDMASTER PIN OR SOCKET TO RJ45 PLUG

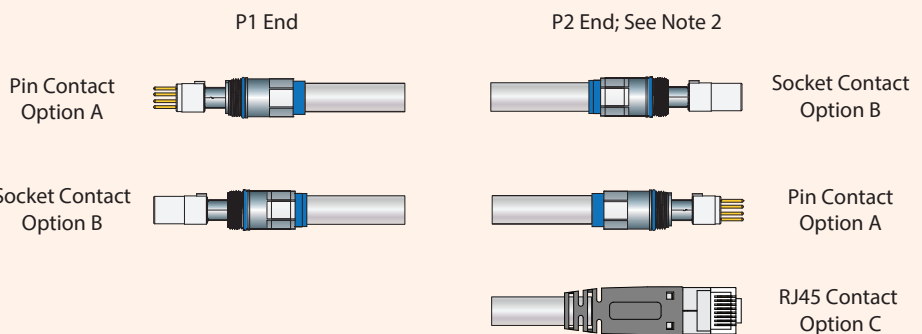
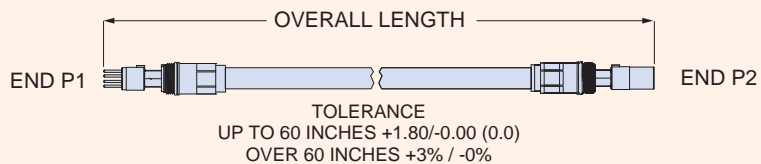

Specifications

- Operating temperature: -65°C. to +200°C. (SpeedMaster) or -40°C. to +85°C (RJ45); cable dependent
- Meets EIA/TIA 568C.2-10 and IEC 60603-7-51 Cat 6A 500 MHz
- Characteristic Impedance: 100 ohms
- Insulation resistance: 200 megohms min.
- Durability: 500 mating cycles

Cable Size

Cable Size	Cable Ø	Cable Size	Cable Ø
1	.280 (7.11)	5	.240 (6.10)
2	.270 (6.86)	6	.230 (5.84)
3	.260 (6.60)	7	.220 (5.59)
4	.250 (6.35)		

HIGH-SPEED SpeedMaster™ Available connector packaging



MIGHTY MOUSE 824 LOCKING PUSH-PULL



- Quick-disconnect coupling
- Audible, visual, and tactile full-mate indicators

Available connector configurations

824-009-06	Plug
824-010-01	In-line Receptacle
824-010-00	Front Panel Mount, Jam Nut Receptacle
824-010-07	Rear Panel Mount, Jam Nut Receptacle

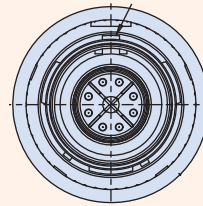

Single Contact Module Insert Arrangement

Ideally suited for CAT5E or CAT6A Ethernet applications

HIPER-D M24308 INTERMOUNTABLE



- Advanced temperature, vibration and EMC/ electrical performance
- Rugged machined one-piece shell

Series 28 In-Line Connectors

280-101M	Plug
280-098F	Receptacle

Series 28 Rear Panel Mount Connectors

280-102M	Plug
280-099F	Receptacle

Series 28 Float Mount Connectors

280-103M	Plug
280-100F	Receptacle

SpeedMaster HiPer-D Insert Arrangements

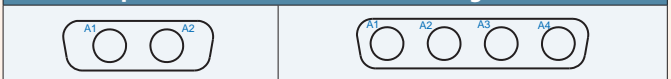

SUPERNINE D38999 SERIES III TYPE



- Advanced performance, "better than QPL" D38999 Series III type bodies and shells
- Optimized for SpeedMaster contact modules

233-219 SpeedMaster SuperNine connectors

G6 = Plug 38999/26	CM = Receptacle, wall mount, metric clinch nuts
05 = Receptacle, in-line	CS = Receptacle, wall mount, standard clinch nuts
07 = Receptacle, jam-nut 38999/24	DO = Receptacle, wall mount, thru holes
00 = Receptacle, wall mount 38999/20	HM = Receptacle, wall mount, metric helicoils
	HS = Receptacle, wall mount, standard helicoils
	TO = Receptacle, wall mount, tapped holes

233-220 SpeedMaster SuperNine PC Tail connectors

00 = Wall mount receptacle with slotted holes, standard standoff threads
10 = Wall mount receptacle with slotted holes, metric standoff threads
CM = Wall mount receptacle with metric clinch nuts
CS = Wall mount receptacle with standard clinch nuts
HM = Wall mount receptacle with metric helicoils
HS = Wall mount receptacle with standard helicoils
07 = Jam-nut receptacle

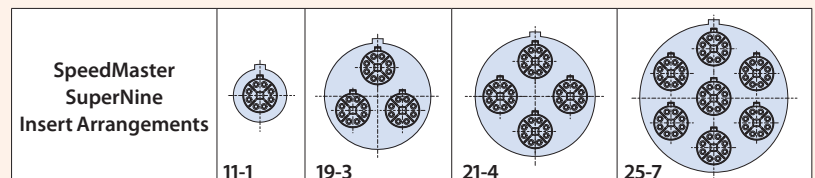

RECOMMENDED BACKSHELL

377NS119 Aluminum Alloy Backshell

ETHERNET - READY
HIGH - SPEED
INDUSTRIAL -
STRENGTH



The faster ruggedized 4/8 pole interconnect system for Ethernet data applications



Glenair series ITH connectors with Ethernet-ready Octobyte™ contacts are available for harsh-environment mass transit applications that depend on sealed environmental (IP67) connector performance. Octobyte contacts, packaged in ruggedized ITH reverse-bayonet connectors, deliver both dedicated Ethernet datalink as well as mixed serial databus and power for high-speed data applications

Octobyte™ contacts are vibration resistant and designed to work with Ethernet cables from CAT 5 to CAT 7A, MVB-WTB, and RG58 Coax. Reverse-bayonet ITH series connectors with Octobyte™ contacts are easy and fast to assemble and deliver reliable locking performance in severe vibration and shock applications.

- For harsh-environment transit, industrial, or marine/subsea applications
- RF Coax applications (RG58 and RG59U cables)
- High-speed interconnect solution for audio, video, and digital displays
- Qualified for use in safety systems, sensors, detection devices, and control panels
- Tested in accordance with:
ISO F0 STP: CAT 7A
EN50173-1 F600-STP: CAT 7
EN50173-1 D STP: CAT 5E



Tested for compliance IAW EN50173-1 standards for CAT5E and CAT7.
Proven performance in numerous rail applications (consult factory for references)

OCTOBYTE CONTACTS FOR ETHERNET CAT 5 · CAT 6 · CAT 7 · COAX · MVB-WBT

How To Order OctoByte contacts	
Sample Part Number	Q 0 8 P -A B1 -XXX -7A
Product Series	OctoByte contacts
Contact Size	0 = contact size 0
Number of Contacts	8 = 8 poles 4 = 4 poles CX = Coax
Contact Gender	P = Male S = Female
Cable O.D. Range/ Coax Cable Type	A = O.D. 6-7 B = O.D. 7-8 C = O.D. 8-9 RG58 = 50 Ohm RG59U = 75 Ohm [Coax only]
Plating	B1 = gold plating
Alternative Color (Cat 7A only)	G14 = Black G14GN = Green G14GY = Grey G14R = Red G14Y = Yellow Omit for standard
Ethernet	7A = Cat 7A AD = Ethernet MVB - WBT Contacts Omit for Cat 5



SERIES ITH CONNECTORS FOR OCTOBYTE CONTACTS

Reverse bayonet-lock connectors

Rugged environmental performance — the perfect OctoByte packaging solution



Dozens of contact arrangements available including hybrid OctoByte, power, and signal.

- Rugged MIL-DTL-5015 type design with fast reverse bayonet coupling
- Rigid dielectric inserts with contact retention clips
- Positive lock technology provides reliable vibration and shock resistance
- Proven performance in even the most rugged applications
- Conforms to the European VG 95234 standard, French (NFF 61030) and British (BS 6853) electrical standards and EEC compliance directives
- Threaded coupling version available, contact factory for ordering information

Ethernet-ready OctoByte solutions for rail and transit applications are available as discrete contacts, packaged in rugged reverse-bayonet ITH series connectors, or as turnkey inside-the-box or environmental cable assemblies, tested and ready for immediate use.



SUPER ITS - ITH OCTOBYTE CONNECTORS

Precision machined connectors with 4/8 pole Octobyte contacts provide high-speed Ethernet connectivity for extreme environmental exposure and corrosion resistance typically needed in rail, mining, and other industrial applications. Convenient reverse bayonet mating provides easy intermateability while the locking three pin bayonet coupler prevents the connector from demating under high shock and high vibration conditions. Accessory thread for attachment of backshells and adapters.

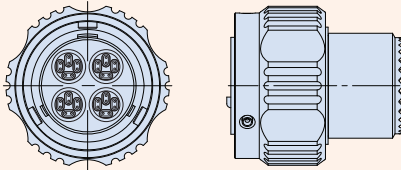

03 - Plug

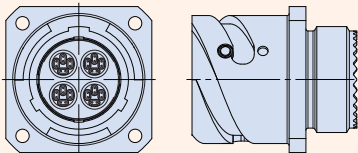

030 - Rear Panel Mount Wall Mount Receptacle

		How To Order								
Sample Part Number:	ITH	030	A	5C	32Q4	S	B0	N0	F6	
Series	ITH									
Contact Size	030 = Rear Panel Mount Wall Mount Receptacle 06 = Straight Plug									
Environmental	A = Non environmental R = Environmental									
Number of Keys	5C = 5 keys									
Insert Arrangements	18-Q1, 32-Q4, 36-Q5, 40-Q7									
Contact Gender	P = Pin contacts (male) S = Socket contacts (female)									
Connector less contact	B0 = contact not supplied (order the contact separately)									
Accessory	N0 = without Backshell. Please consult the factory									
Plating	F6 = Electrodeposited black paint (cataphoresis), RoHS compliant F7 = Black Zinc Nickel, RoHS compliant									

FRONT VIEW RECEPTACLE CONNECTORS



18-Q1

32-Q4

36-Q5

40-Q7

How to order - Super ITS-ITH OctoByte connectors

SERIES ITS - ITH OCTOBYTE CONNECTORS

Precision machined connectors with 4/8 pole OctoByte, high-speed Ethernet contacts and power contacts provide both network connectivity and power distribution in one connector. Designed for extreme environmental exposure and corrosion resistance typically needed in rail, mining, and other industrial applications. Convenient reverse bayonet mating provides easy intermateability while the locking three pin bayonet coupler prevents the connector from demating under high shock and high vibration conditions. Accessory thread for attachment of backshells and adapters.

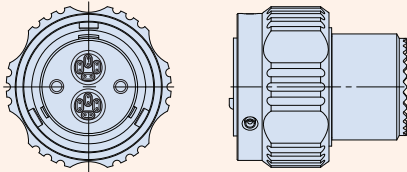

03 - Plug

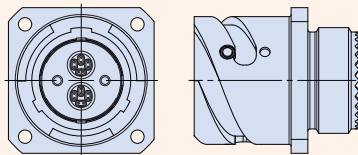

030 - Rear Panel Mount Wall Mount Receptacle

		How To Order									
Sample Part Number:	ITH	030	A	5C	28-OB4	S	B0	N0	F6		
Series	ITH										
Contact Size	030 = Rear Panel Mount Wall Mount Receptacle 06 = Straight Plug										
Environmental	A = Non environmental R = Environmental										
Number of Keys	5C = 5 keys										
Insert Arrangements	28-OB4, 36-OB7										
Contact Gender	P = Pin contacts (male) S = Socket contacts (female)										
Connector less contact	B0 = contact not supplied (order the contact separately)										
Accessory	N0 = without Backshell. Please consult the factory										
Plating	F6 = Electrodeposited black paint (cataphoresis), RoHS compliant F7 = Black Zinc Nickel, RoHS compliant										

FRONT VIEW PLUG CONNECTORS



28-OB4
2 OCTOBYTE
2 SIZE 8 CONTACTS



36-OB7
3 OCTOBYTE
4 SIZE 8 CONTACTS

RUGGEDIZED
RJ45 / USB
FIELD
CONNECTORS



SuperSeal RJ45 and USB field connectors. Now available for USB SuperSpeed 3.0



USB
SuperSpeed 3.0
Compatible

Military-grade, ruggedized field connectors that deliver improved environmental sealing, EMI/RFI grounding, and a broader range of wire termination options for RJ45 and USB—now for SuperSpeed 3.0



Available ruggedized memory stick
32GB, 64GB, and 128GB versions

- New SuperSpeed USB 3.0 protocol support
- Superior sealing—IP67 unmated—for complete system protection against water, sand and dust
- Highly durable SuperSeal™ insert design, provides enhanced operating temperature, increased life-cycle, and rugged vibration and shock performance
- Crimp, solder-cup, PC tail and cable assemblies

SuperSeal High-Speed Ruggedized RJ45/USB connectors and cables



SuperSpeed USB 3.0

NEW SUPERSPEED USB 3.0 RUGGEDIZED FIELD CONNECTORS



Cable plug

Wall mount receptacle with metric clinch nuts

Wall mount receptacle with slotted holes

Wall mount receptacle with round holes

Jam nut mount Receptacle

TURNKEY SUPERSPEED USB 3.0 CABLE ASSEMBLIES AND JUMPERS



Glenair SuperNine USB 3.0 cable jumpers, SuperSeal to standard USB Type A and Micro-B connectors

SuperSeal USB 3.0 connectors are available as turnkey cable jumpers. Rugged field connector styles—including plug, wall mount and jam-nut receptacles—may be cabled with commercial 3.0 connector types including male Type A, female Type A, and male Micro B. Assemblies may be ordered with straight or right angle cable exit. In addition, the USB 3.0 insert may be ordered in horizontal or vertical orientation to provide protection against mis-mating. Maximum overall length is 15 feet.



SUPPORTED USB 3.0 CONNECTOR TYPES



USB 3.0 male Type A

USB 3.0 female Type A

USB 3.0 male Micro B



USB ORIENTATION OPTIONS

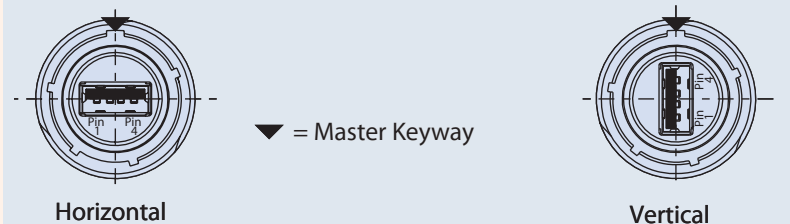

SuperSeal High-Speed Ruggedized RJ45/USB connectors and cables

Available connector packaging



AVAILABLE TERMINATION OPTIONS



Solder Cup



PC tail



Crimp Contact



Jack-to-Jack



EMI Filtered



Quadrax



MIL-STD-1560 Arrangements



Turnkey Cordsets



SuperSeal™ MIL-DTL-38999 Series III Type RJ45 Connectors and Cordsets plus NEW Transient Voltage Suppression Solutions



SuperSeal™ MIL-DTL-Series 39999 Series III Type USB 2.0 Connectors and Cordsets



ITS SuperSeal™ (5015 Intermountable) Reverse-Bayonet RJ45 Connectors



ITS SuperSeal™ (5015 Intermountable) Reverse-Bayonet USB 2.0 Connectors

SuperSeal High-Speed Ruggedized RJ45/USB connectors and cables



Available connector packaging



IPT SuperSeal™ MIL-DTL-26482 Type Bayonet RJ45 Connectors



IPT SuperSeal™ MIL-DTL-26482 Type Bayonet USB Connectors



SuperSeal™ MIL-DTL-28840 Type RJ12/RJ45 and USB Shipboard Connectors



SuperSeal™ Series 801, 804 and 805 Mighty Mouse Micro USB 2.0 Connectors

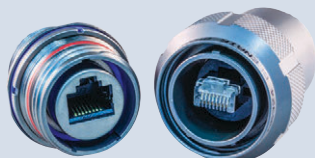

SuperSeal™ Series 801, 804 and 805 Mighty Mouse RJ45 Connectors



SuperSeal™ Series 801, 804 and 805 Mighty Mouse Standard USB 2.0 Connectors

HIGH-SPEED
VERSALINK™
DIFFERENTIAL
TWINAX

VersaLink™

Ultra Miniature Micro-D
Connectors with High-
Speed VersaLink
Contact Technology



Innovative differential Twinax contact technology in ruggedized, high-density mil-spec connector packaging

High-speed serial data protocols (USB 3.1 Gen2, USB-C, SATA, PCIe, DisplayPort, and HDMI) all have transmission rates in the 10Gb/s+ range for each data pair. In order to provide truly high-speed signal integrity for these bandwidth-dependent protocols, Glenair has invented a new contact technology called VersaLink™ which delivers outstanding impedance matching and cross-talk isolation at both the cable-to-connector interface, as well as between connector and board. VersaLink is a highly-engineered differential Twinax contact module that may be packaged in a wide range of both circular and rectangular connector formats such as the MIL-DTL-83513 Micro-D. This high-density package solution provides mating reliability, ruggedness, signal integrity, and deployment simplicity.

Data-intensive servers, computers and peripheral devices in mission-critical applications require a new generation of shielded contact technology and tried-and-true connector package performance. Both are exquisitely realized in the VersaLink Micro-D.

- VersaLink: shielded differential Twinax interconnect solution
- Signature Glenair design intermountable in standard Micro-D footprints
- Higher speed and density than mil-spec style Twinax solutions
- Individually shielded pairs result in virtually zero cross talk
- Hybrid arrangements with VersaLink contact modules and standard Micro-D inserts for signal and power

HIGH-SPEED VersaLink™ Micro-D



Military-standard Micro-D connectors with “zero crosstalk” VersaLink™ Twinax contact modules

CONNECTOR CONFIGURATIONS

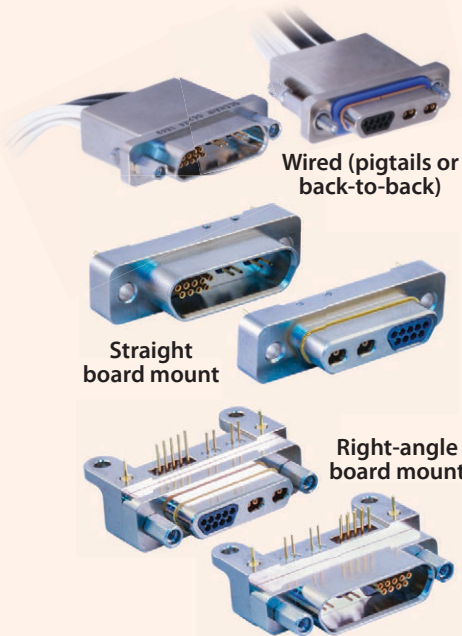

EMI SHIELDING AND ENVIRONMENTAL SEALING

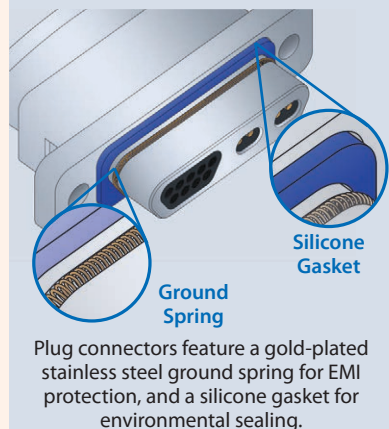

SUPPORTED HIGH-SPEED PROTOCOLS AND APPLICATIONS

Networking Protocols	Peripheral and Display Protocols	
10Gb Ethernet 40Gb Ethernet	DVI (Digital Visual Interface) HDMI 2.0 (High-Definition Multimedia Interface) DisplayPort 1.2 SATA 3 (Serial AT Attachment)	USB 3.0 (Universal Serial Bus) USB 3.1 Type C (Universal Serial Bus) USB 3.2 (Universal Serial Bus) PCIe 3 (Peripheral Component Interconnect)

CONTACT ARRANGEMENTS

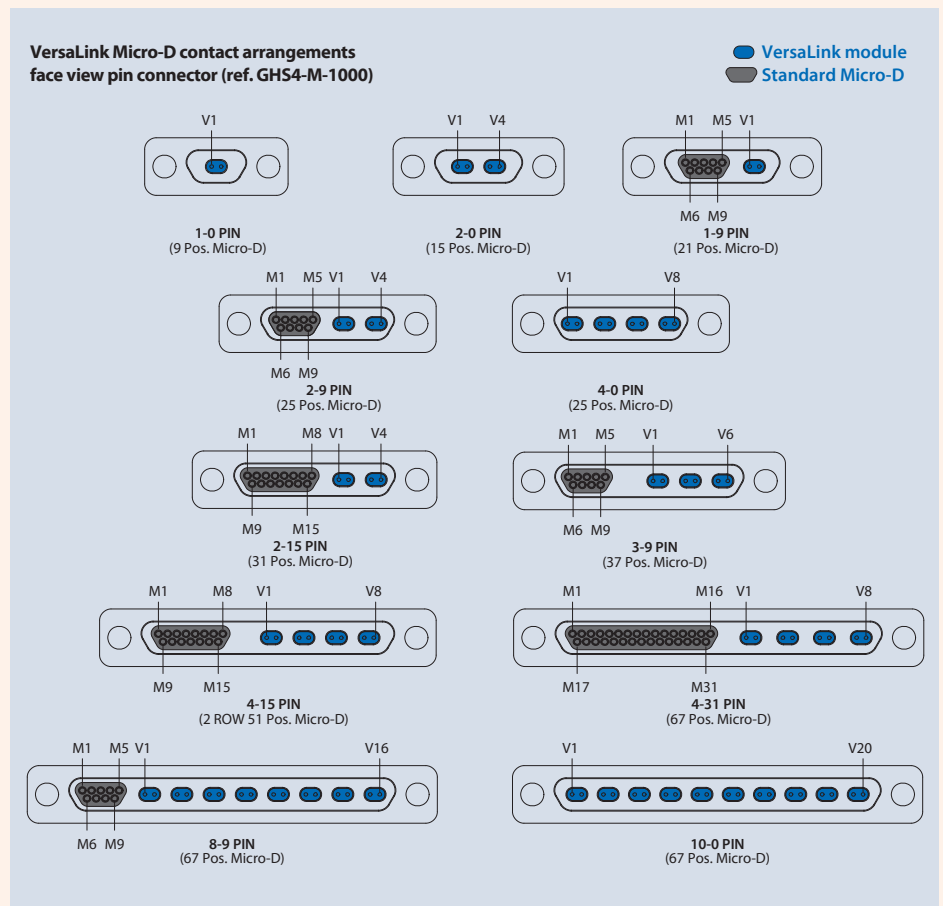

MATERIALS AND FINISHES

Connector Shell: Aluminum Alloy 6061
 Insulator (V): Rigid Dielectric. Insulator (M): Liquid Crystal Polymer (LCP) or Polyphenylene Sulfide (PPS)
 Flange Seal: Fluorosilicone Rubber, Blue
 Pin Contact: Copper Alloy, Gold over Nickel Plating
 Socket Contact: Copper Alloy, Gold over Nickel Plating
 Ground Spring: Stainless Steel, Gold Plating
 Ground Pin: Copper Alloy, Gold Over Nickel Plating
 Hardware: 300 Series Stainless Steel, Passivated
 Encapsulant: Epoxy Resin Hysol EE4215

PERFORMANCE SPECIFICATIONS

Current Rating: 3 Amp (Micro-D pins)
 DWV (Contact M): 600 VAC Sea Level
 Insulation Resistance (Contact M): 5000 Megohms Minimum
 Contact Resistance (Contact M): 8 Milliohms Maximum
 Low Level Contact Resistance: 32 Milliohms Maximum
 Operating Temperature: -55°C To 125°C
 Mating Force (Contact M): (10 Ounces) X (# Of Contacts)
 Mating Force (Contact V): (5 Ounces) X (# Of Contacts)

HIGH-SPEED VersaLink™ Micro-D



How-to-order Wired connectors



How To Order VersaLink Micro-D Wired Connectors	
Sample Part Number	GHS4-M 2 L 2-9 P A 6 J I -18 K N
Series	GHS4-M = Glenair VersaLink Micro-D
Shell Finish	2 = Nickel 5 = Gold
Insulator Material	L = LCP or PPS
Contact Layout (V-M)	1-0, 2-0, 1-9, 2-9, 4-0, 2-15, 3-9, 4-15, 4-31, 8-9, 10-0
Contact Type¹	P = Pin (Single-End Plug) S = Socket (Single-End Receptacle) GP = Double-End Cable, Pin Connectors Both Ends GS = Double-End Cable, Socket Connectors Both Ends CS = Double-End Cable, Pin and Socket [designation is for Micro-D contacts, see note 1 below]
VersaLink Cable Type	A = Glenair Cable 963-043-26 (100 Ohm, +105°C Max)
Discrete Wire Gage (AWG)²	4 = #24 6 = #26 8 = #28 0 = #30 (J Wire Type Only)
Discrete Wire Type²	K = M22759/11 600 VRMS Teflon (TFE) J = M22759-33 600 VRMS Modified Cross-Linked Tefzel (ETFE) E = NEMA HP3-EB 600 VRMS Type E M16878/4 (TFE)
Discrete Wire Color²	1 = White 5 = Color-Coded Stripes per MIL-STD-681 7 = Ten Color Repeating
Wire Length	Wire Length in Inches, 6 Inch Minimum
Hardware³	P, M, M1, S, S1, L, K (See Mounting Hardware Designations table below)
Shield and Jacket Option	X - ArmorLite Braided Microfilament Stainless Steel shield with E-CTFE Halar "Expando" Jacket W - ArmorLite Braided Microfilament Stainless Steel shield Z - 75% Braided AmberStrand shield with E-CTFE Halar "Expando" Jacket V - 75% Braided AmberStrand shield T - 100% Braided AmberStrand shield with E-CTFE Halar "Expando" Jacket S - 100% Braided AmberStrand shield C - Braided shield (Nickel Over Copper) with E-CTFE Halar "Expando" Jacket A - Braided shield (Nickel over Copper) N - No Shield, No Jacket (customer to install)

1 - Plug connector uses Pin Micro-D contacts and Socket VersaLink contacts. Receptacle uses Socket Micro-D contacts and Pin VersaLink contacts. GP and GS cable ends rotated 180° out of phase due to connector symmetry.

2 - Omit wire information for VersaLink-only contact layouts (1-0, 2-0, 4-0, 10-0)

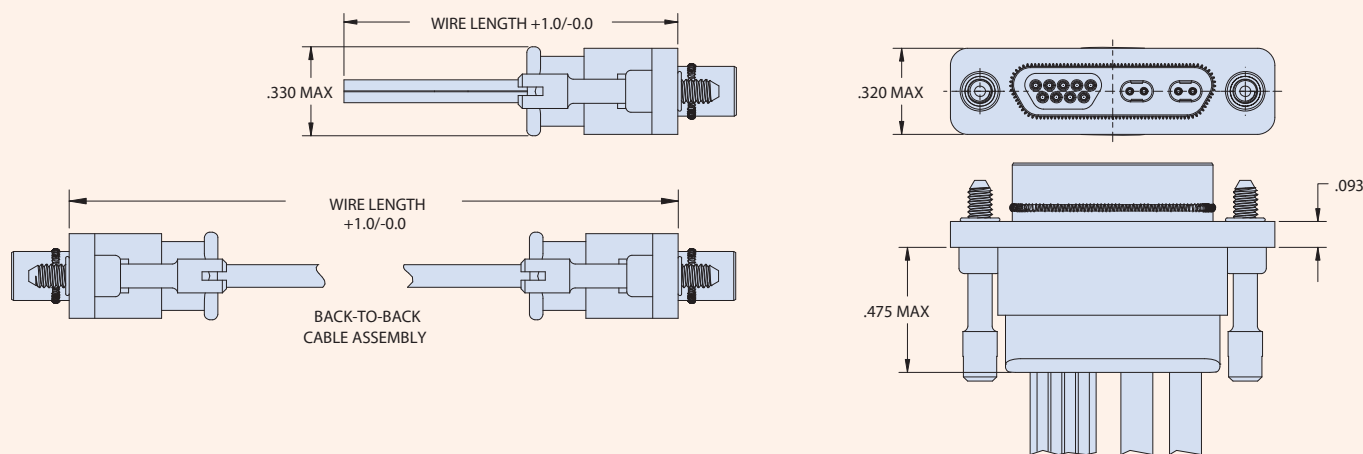
3 - Hardware is always required to ensure connector pair is fully mated when installed

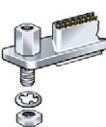
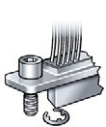
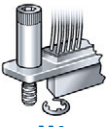
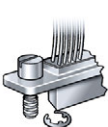
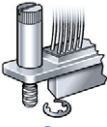
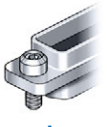

Mounting Hardware Designations						
						
P Jackpost	M Hex Head Jackscrew	M1 Hex Head Jackscrew, Extended	S Slot Head Jackscrew	S1 Slot Head Jackscrew, Extended	L Hex Head Jackscrew, Non- Removable	K Slot Head Jackscrew, Non- Removable Extended

How-to-order PCB connectors, straight and right-angle

How To Order VersaLink Micro- D Straight Board-Mount Connectors

Sample Part Number	GVLM	2	L-	2-9	P	BS	PN	-110
Series	GVLM = Glenair VersaLink Micro-D							
Shell Finish	2 = Nickel 5 = Gold							
Insulator Material	L = LCP or PPS							
Contact Layout (V-M)	1-0, 2-0, 1-9, 2-9, 4-0, 2-15, 3-9, 4-15, 4-31, 8-9, 10-0							
Contact Type¹	P = Pin (Plug) S = Socket (Receptacle) [designation is for Micro-D contacts, see note 1 below]							
Termination Type	BS = Board Straight							
Hardware²	PN = Extended Jackpost with Hex Nut and Lockwasher							
PC Tail Length³	-.080, -.110, -.140 (Length in Inches ±.015)							

1 - Plug connector uses Pin Micro-D contacts and Socket VersaLink contacts. Receptacle uses Socket Micro-D contacts and Pin VersaLink contacts
 2 - Hardware is always required to ensure connector pair is fully mated when installed 3 - PC Tails solder-dipped in 60/40 Tin-Lead solder

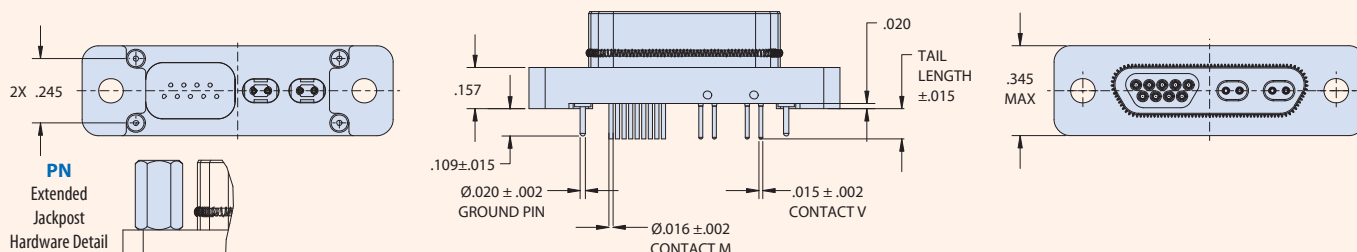

Ref. GVLM-1000 for PCB layouts.
 For optimal performance, reference Glenair Application note AN0005

How To Order VersaLink Micro-D Right-Angle Board-Mount Connectors

Sample Part Number	GVLM	2	L-	2-9	P	BR	P	T	-110
Series	GVLM = Glenair VersaLink Micro-D								
Shell Finish	2 = Nickel 5 = Gold								
Insulator Material	L = LCP or PPS								
Contact Layout (V-M)	1-0, 2-0, 1-9, 2-9, 4-0, 2-15, 3-9, 4-15, 4-31, 8-9, 10-0								
Contact Type¹	P = Pin (Plug) S = Socket (Receptacle) [designation is for Micro-D contacts, see note 1 below]								
Termination Type	BR = Board Right Angle								
Hardware²	P = Jackpost								
Threaded Insert Option	T = Threaded Insert in Board-Mount Hole Omit for Through-Hole								
PC Tail Length³	.080, .110, .140 (Length in Inches ±.015)								

1 - Plug connector uses Pin Micro-D contacts and Socket VersaLink contacts. Receptacle uses Socket Micro-D contacts and Pin VersaLink contacts
 2 - Hardware is always required to ensure connector pair is fully mated when installed
 3 - PC Tails solder-dipped in 60/40 Tin-Lead solder

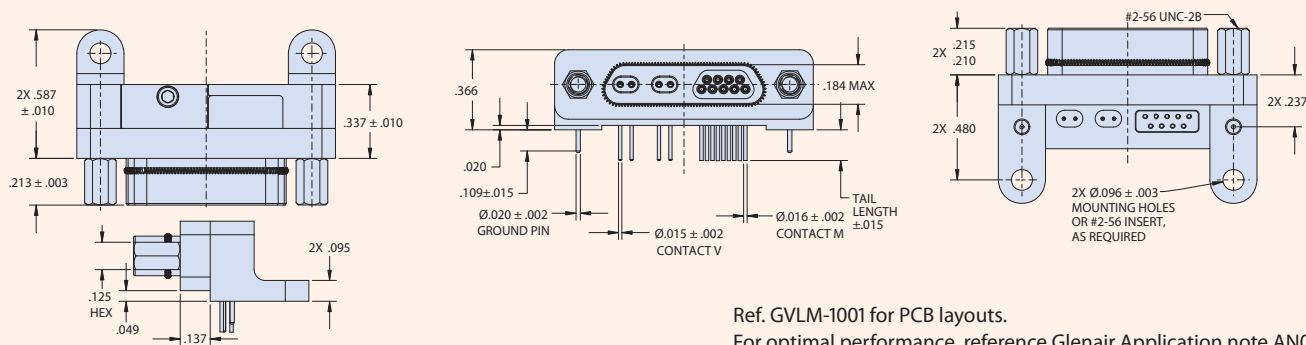

Ref. GVLM-1001 for PCB layouts.
 For optimal performance, reference Glenair Application note AN0005

HIGH-SPEED
VERSALINK™
DIFFERENTIAL
TWINAX BYPASS
JUMPERS

VersaLink™
BRIDGE

VersaLink Bridge: 100 Ohm connectors and jumpers for high-speed board applications

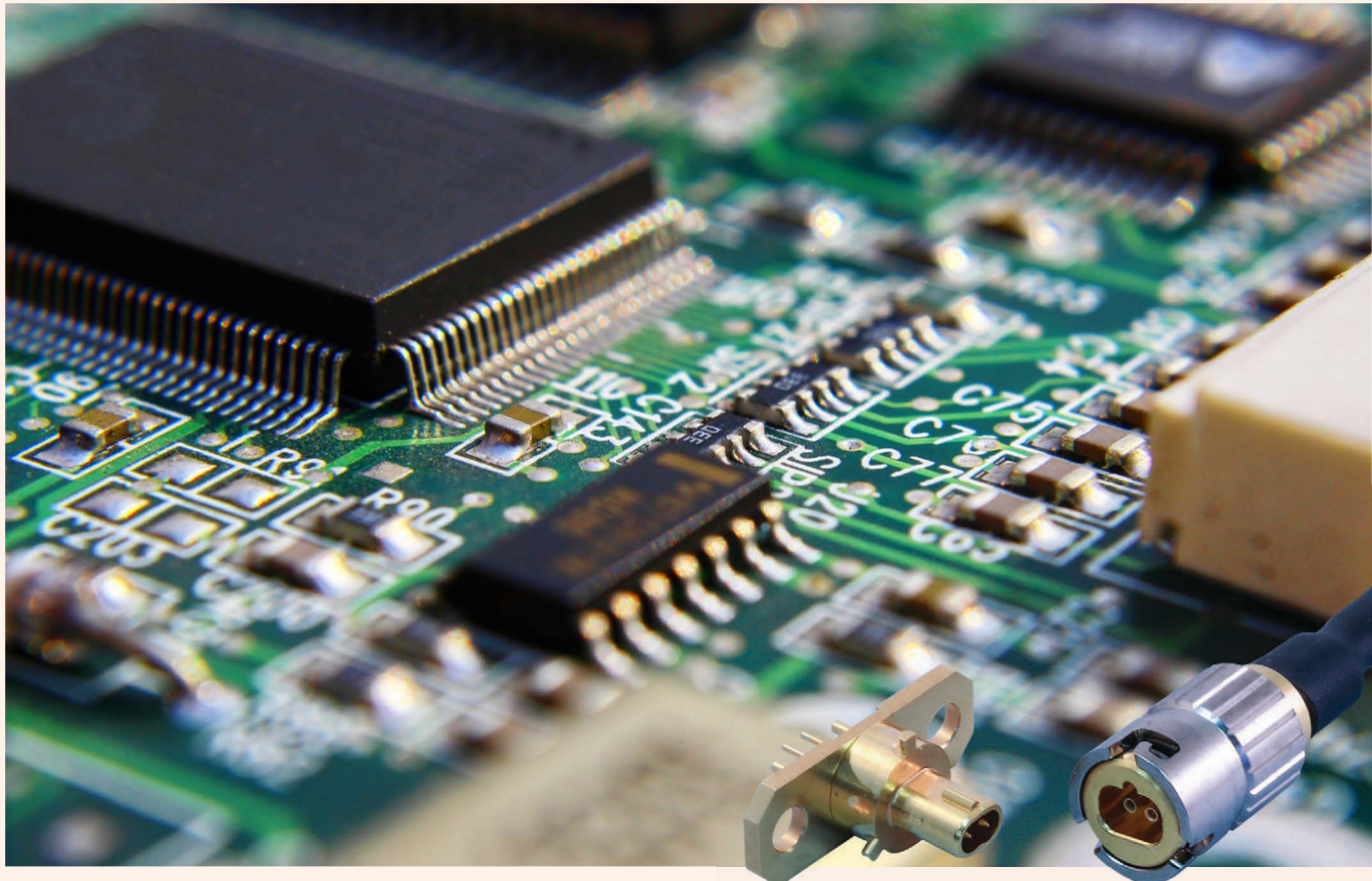

VersaLink Bridge: bypass high-loss board traces with a low insertion-loss and low signal-latency point-to-point Twinax jumper

High-speed data transmission from one PCB to another, from one side of a backplane to another, or even from one side of a complex embedded system to another, is frequently accomplished by routing high-speed traces on a dedicated high-speed signal layer. This is a complex assignment—fraught with potential for impedance discontinuities and unacceptable insertion loss—as traces must navigate difficult and/or long routing paths around via columns and other board irregularities. The Glenair VersaLink Bridge is a high-density, micro-form factor twinax connector / jumper assembly used to bridge the gap between point A and point B on the board (such as between two SML integrated circuit chips) with better signal integrity than native board traces can ever deliver. VersaLink Bridge is equally capable of dramatically reducing insertion loss and signal latencies for data traffic between an ASIC and the I/O.

Right-angle bayonet-lock version for high shock and vibrate applications

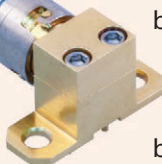

VERSALINK BRIDGE FEATURES

- Small footprint, high-density solution
- Versatile solder-mount or screw-mount board termination
- 100 Ohm differential Twinax
- Push-pull mating or bayonet-lock for high vibration and shock applications
- Keyed polarization prevents mis-mating
- Low insertion loss and low signal latencies for high data rate board transmissions

HIGH-SPEED VersaLink™ Bridge



Differential Twinax “bypass” connector and jumper assemblies

AVAILABLE CONFIGURATIONS: QUICK-DISCONNECT

Quick-disconnect plug	QDC Jack board pin straight screw mount	QDC Jack board pin straight solder mount	QDC Jack board pin right-angle screw mount	QDC Jack board pin right-angle solder mount

AVAILABLE CONFIGURATIONS: BAYONET-LOCK

Bayonet-lock plug	Bayonet-lock Jack board pin straight screw mount	Bayonet-lock Jack board pin straight screw mount

Recommended Cable for Plug Connectors

Cable P/N	Cable Construction	Wire Gauge	Impedance	Max. Overall Size
963-043-26	Twinax In-Line	26	100 Ω	.121" X .076"

MATERIALS AND FINISHES

Contacts: Copper alloy / gold
 Insulators: Superior rigid dielectric
 Body: Copper alloy / gold
 Ferrules (plugs): Copper alloy / electroless nickel
 Spring (plugs): Music wire

ELECTRICAL PARAMETERS

(for Board Connectors)

Impedance: 100 Ohms
 DWV: 500 RMS
 IR: 5000 Megaohms min. at 200 VDC

Reduced size and weight: A side-by-side comparison of a standard SMA coax connector (left) and VersaLink.

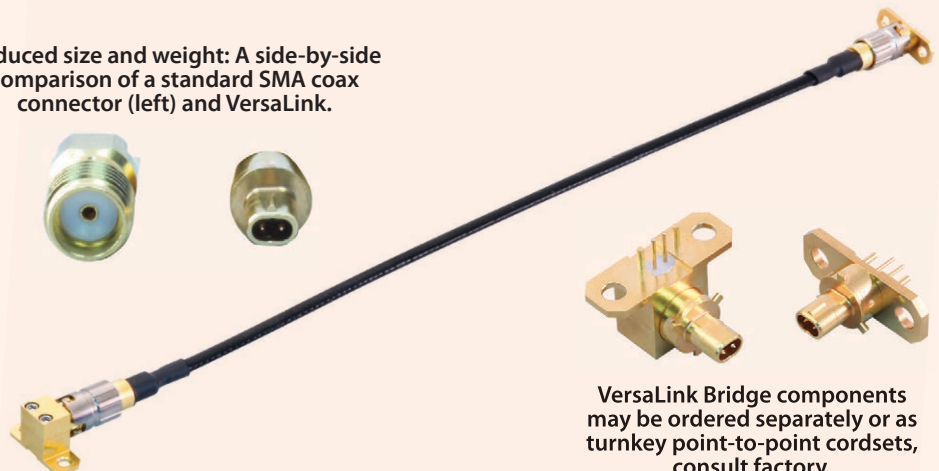

VersaLink Bridge components may be ordered separately or as turnkey point-to-point cordsets, consult factory.

HIGH-SPEED VersaLink™ Bridge

QDC Differential Twinax “bypass” connectors How-to-order



How To Order VersaLink Bridge Quick-Disconnect Plug Connectors

Sample Part Number	853-051
Series	853-051 VersaLink Bridge Plug socket QDC connectors

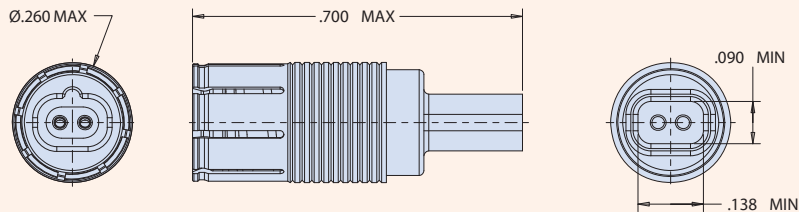

How To Order VersaLink Bridge Quick-Disconnect Straight Board Connectors

Sample Part Number	853-052	-1	G	-.140
Series	853-052 VersaLink Bridge straight board pin QDC connectors			
Mounting Style	1 = Solder Mount 2 = Screw Mount			
PC Tail Finish	S = Solder dipped in 63/37 Tin/Lead G = Gold Plated			
PC Tail Length	-.140, -.110, -.080 (length in inches)			

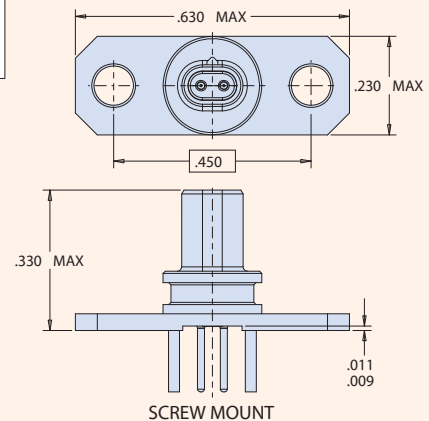
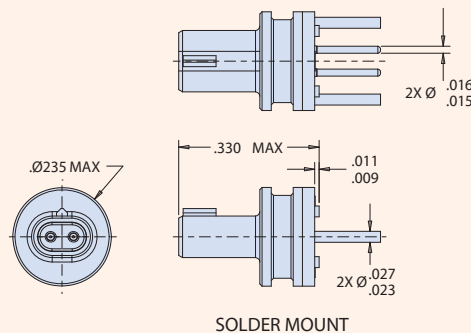
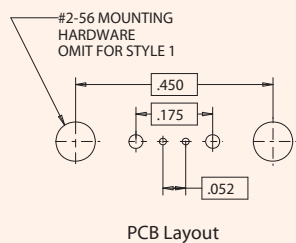

How To Order VersaLink Bridge Quick-Disconnect Right-Angle Board Connectors

Sample Part Number	853-054	-1	G	-.140
Series	853-054 VersaLink Bridge Right-angle board pin QDC connectors			
Mounting Style	1 = Solder Mount 2 = Screw Mount			
PC Tail Finish	S = Solder dipped in 63/37 Tin/Lead G = Gold Plated			
PC Tail Length	-.140, -.110, -.080 (length in inches)			

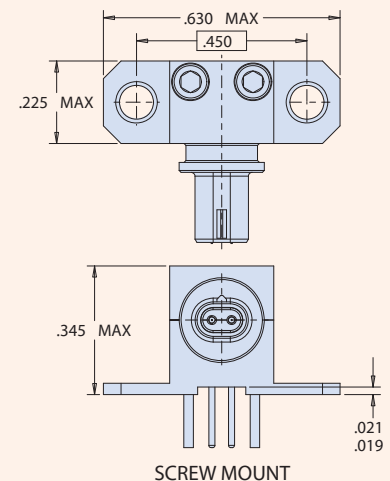
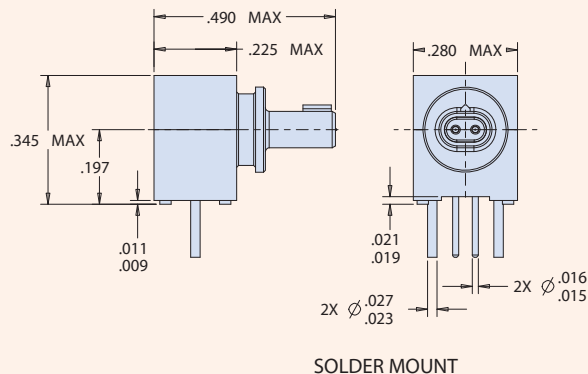
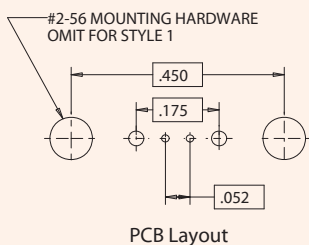

HIGH-SPEED VersaLink™ Bridge



Bayonet-Lock Differential Twinax “bypass” connectors How-to-order

How To Order VersaLink Bridge Bayonet-Lock Plug Connectors

Sample Part Number	853-064
Series	853-064 VersaLink Bridge Plug socket bayonet connectors

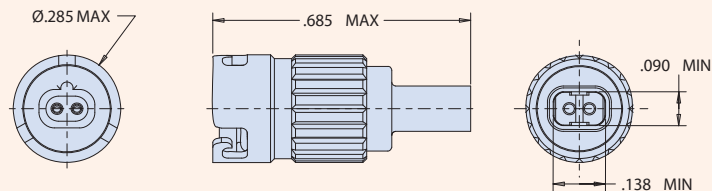

How To Order VersaLink Bridge Bayonet-Lock Straight Board Connectors

Sample Part Number	853-065	G	-.140
Series	853-065 VersaLink Bridge Bayonet-lock straight board pin connector		
PC Tail Finish	S = Solder dipped in 63/37 Tin/Lead G = Gold Plated		
PC Tail Length	-.140, -.110, -.080 (length in inches)		

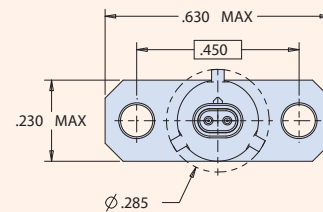
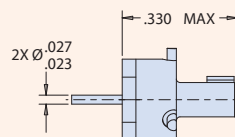
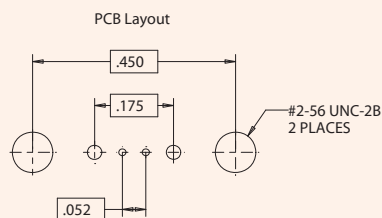
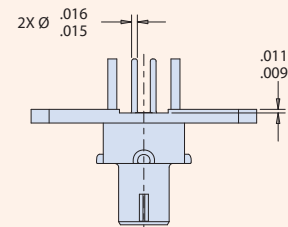

How To Order VersaLink Bridge Bayonet-Lock Right-Angle Board Connectors

Sample Part Number	853-067	G	-.140
Series	853-067 VersaLink Bridge Bayonet-lock right-angle board pin connector		
PC Tail Finish	S = Solder dipped in 63/37 Tin/Lead G = Gold Plated		
PC Tail Length	-.140, -.110, -.080 (length in inches)		

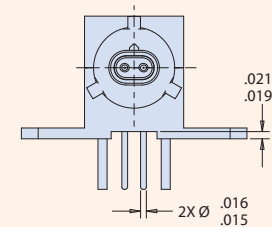
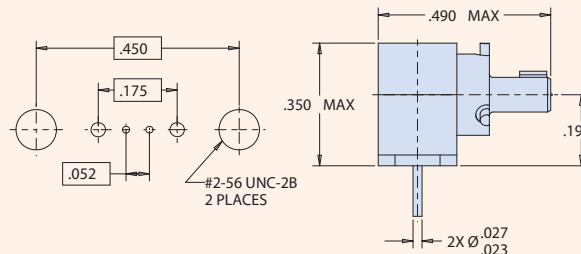
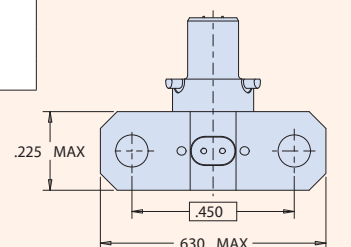



High-Speed Micro-D:
Smallest and Lightest
Aerospace-Grade
High-Speed Connector
Solution



The High-Speed Micro-D is a 1 Amp pre-wired cable and PCB solution with 10+ Gb/sec. performance per differential pair. Auxiliary EMC ground springs on plug and integral contact separation architecture ensures data integrity and low attenuation performance.

High-Speed Micro-D connectors and cables are optimized for high-speed digital datalink protocols with machined-shell packaging, low attenuation contact spacing, and ultra low PPS dielectric insulators.



- Pre-wired factory cordsets and PCB connectors
- Unique contact isolation and spacing for optimal high-speed performance
- Standard layouts support maximum #28 AWG wire
- Ultra-low dielectric material combined with optimized contact size and spacing
- Precision-machined shells with gold or nickel plating
- Hybrid contact solutions available with 3 amp and 1 amp TwistPin contacts (perfect for USB 3.0 SuperSpeed applications)

HIGH-SPEED Micro-D



The miniature high-speed connector with mil-spec pedigree connector and contact packaging

SUPPORTED HIGH-SPEED PROTOCOLS

Shell Sizes and contact arrangements optimized for today's popular high-speed protocols

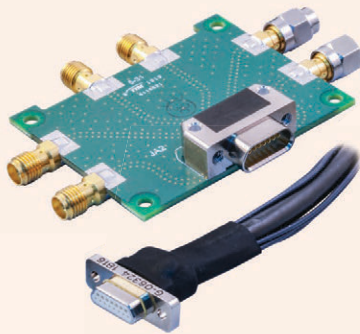

21	21	25	21
Display Port 1.2	HDMI 2.0	DVI-D Dual	DVI-D Single
9	15	9	15
eSATA/SATA 3	USB 3.0	USB 2.0	Up To: Cat 6A (10GBASE-T)

Micro-D High-Speed configurations include wired assemblies and straight or 90° PCB-mount connectors. Insert arrangements feature 1 Amp Nanominiature TwistPin contacts. Hybrid 1Amp/3Amp arrangements for USB 3.0 SuperSpeed are also available. All designs have been tested for today's popular high-speed protocols.

EMI SHIELDING AND ENVIRONMENTAL SEALING

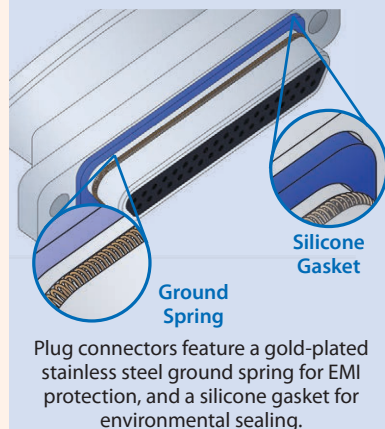

High-Speed Micro-D contact arrangements face view pin connector

- high-speed signal pair
- signal-pair drain wire
- low-speed signal or power contacts

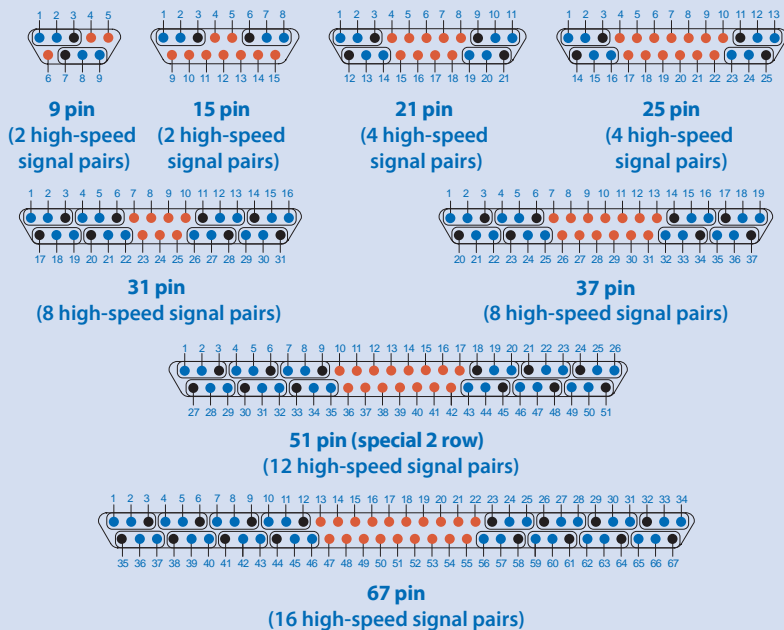

MATERIALS AND FINISHES

Connector Shell: Aluminum Alloy 6061
 Insulator: Polyphenylene Sulfide (PPS)
 Flange Seal: Fluorosilicone Rubber, Blue
 Pin Contact: Copper Alloy, Gold over Nickel Plating
 Socket Contact: Copper Alloy, Gold over Nickel Plating
 Ground Spring: Stainless Steel, Gold Plating
 Hardware: 300 Series Stainless Steel, Passivated
 Epoxy Resin Hysol EE4215 and Stycast 2850FT/Catalyst 11

*Contact factory for custom configurations supporting up to 3 Amps.

**Add (10 Ounces) X (# of 3 Amp Contacts) for mating force for configurations with 3 Amp contacts

PERFORMANCE SPECIFICATIONS

Current Rating: 1 Amp*
 DWV: 600 VAC Sea Level
 Insulation Resistance: 5000 Megohms Minimum (500 VDC)
 Contact Resistance: 80 Milliohms Maximum
 Operating Temperature: -55°C To 125°C
 Mating Force: (7 Ounces) X (# of 1 Amp Contacts)**
 Durability: 500 Mating Cycles



How-to-order GHSM Shielded Cable Assembly Connectors

How To Order High-Speed Micro-D Wired Connectors	
Sample Part Number	GHSM 2 R -31 P -A 8 J 1 -18 L A
Series	GHSM = Glenair High-Speed Micro-D
Shell Finish	2 = Nickel 5 = Gold
Insulator Material	R = PPS
Contact Layout	9, 15, 21, 25, 31, 37, 51-2, 67
Contact Type	P = Pin (Single-End Plug) S = Socket (Single-End Receptacle) GP = Double-End Cable, Pin Connectors Both Ends GS = Double-End Cable, Socket Connectors Both Ends CS = Double-End Cable, Pin and Socket
High Speed Cable Type	A = Glenair Cable 963-043-26 (100 Ohm, +105°C Max) B = Glenair Cable 963-129-28 (90 Ohm)
Discrete Wire Gage (AWG)	8 = #28 0 = #30 (J Wire Type only)
Discrete Wire Type	K = M22759/11 600 VRMS Teflon (TFE) J = M22759/33 600 VRMS Modified Cross-Linked Tefzel (ETFE)
Discrete Wire Color	1 = White 7 = Ten Color Repeating
Wire Length	Wire Length in Inches, 6 Inch Minimum
Mounting Hardware¹	L, M, P, S , (See Mounting Hardware Designations table below)
Shield and Jacket Option	X - ArmorLite Braided Microfilament Stainless Steel shield with E-CTFE Halar "Expando" Jacket W - ArmorLite Braided Microfilament Stainless Steel shield Z - 75% Braided AmberStrand shield with E-CTFE Halar "Expando" Jacket V - 75% Braided AmberStrand shield T - 100% Braided AmberStrand shield with E-CTFE Halar "Expando" Jacket S - 100% Braided AmberStrand shield C - Braided shield (Nickel Over Copper) with E-CTFE Halar "Expando" Jacket A - Braided shield (Nickel over Copper) N - No Shield, No Jacket (customer to install)
¹ - Hardware is always required to ensure connector pair is fully mated when installed	

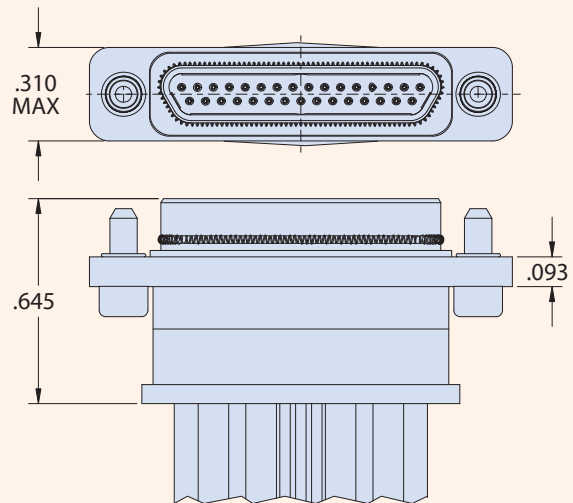
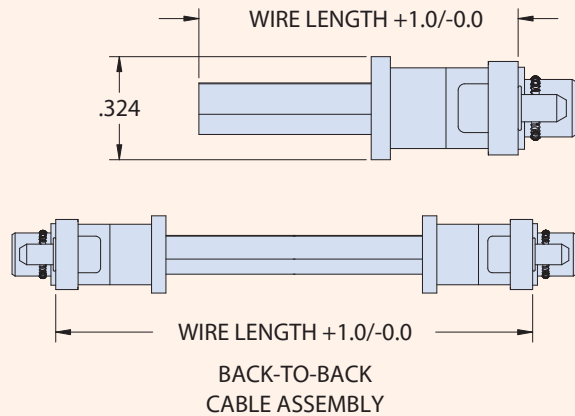

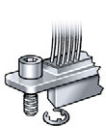
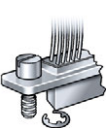
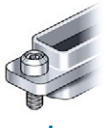
Mounting Hardware Designations			
			
P Jackpost	M Hex Head Jackscrew	S Slot Head Jackscrew	L Hex Head Jackscrew, Non-Removable

How-to-order

GHSM-BSS Board Straight Surface Mount Connectors

How To Order High-Speed Micro-D Board Straight Surface Mount Connectors	
Sample Part Number	GHSM 2 R -25 S BSS PU
Series	GHSM = Glenair High-Speed Micro-D
Shell Finish	2 = Nickel 5 = Gold
Insulator Material	R = PPS
Contact Layout	9, 15, 21, 25, 31, 37, 51-2, 67
Contact Type	P = Pin (Plug) S = Socket (Receptacle)
Termination Type	BSS = Board Straight Surface Mount
Jackpost Option (see table below)	PN = Extended Jackpost for .062" PCB RN = Extended Jackpost for .196" PCB PU = Short Jackpost and Threaded Insert R2U = .032" Panel R3U = .047" Panel R4U = .062" Panel R5U = .094" Panel R6U = .125" Panel R7U = .080" Panel Rear Panel Jackpost with Threaded Insert

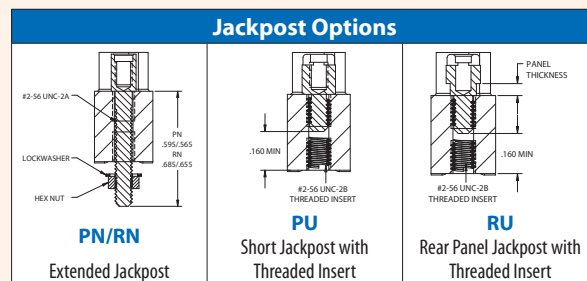
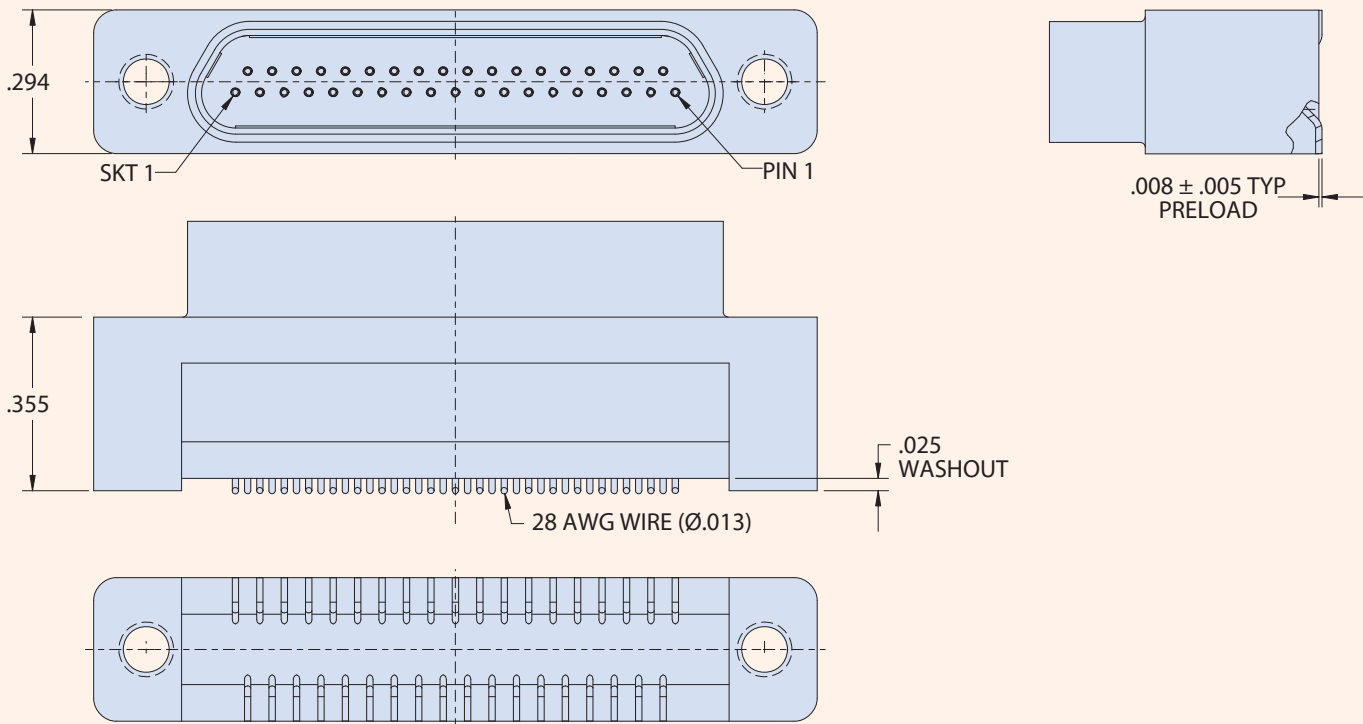

How-to-order GHSM-HBR Hybrid Board Right-Angle connectors

How To Order High-Speed Micro-D Hybrid Board Right Angle Connectors									
Sample Part Number	GHSM	2	R	-25	S	HBR	P	T	-.110
Series	GHSM = Glenair High-Speed Micro-D								
Shell Finish	2 = Nickel 5 = Gold								
Insulator Material	R = PPS								
Contact Layout	9, 15, 21, 25, 31, 37, 51-2, 67								
Contact Type	P = Pin (Plug) S = Socket (Receptacle)								
Termination Type	HBR = Hybrid Board Right Angle								
Jackpost Option (see table below)	P = Jackpost		Jackposts for Rear Panel Mounting						
	L = Hex Head Jackscrew (non-removable)		R1 = .032" Panel	R2 = .047" Panel					
			R3 = .062" Panel	R4 = .093" Panel					
			R5 = .125" Panel	R6 = .080" Panel					
Threaded Insert Option	T = Threaded Insert in Board Mounting Hole Omit for Thru-Hole								
Right-Angle Lead Length	-.080, -.110, -.140, -.172 (Length in Inches ±.015)								

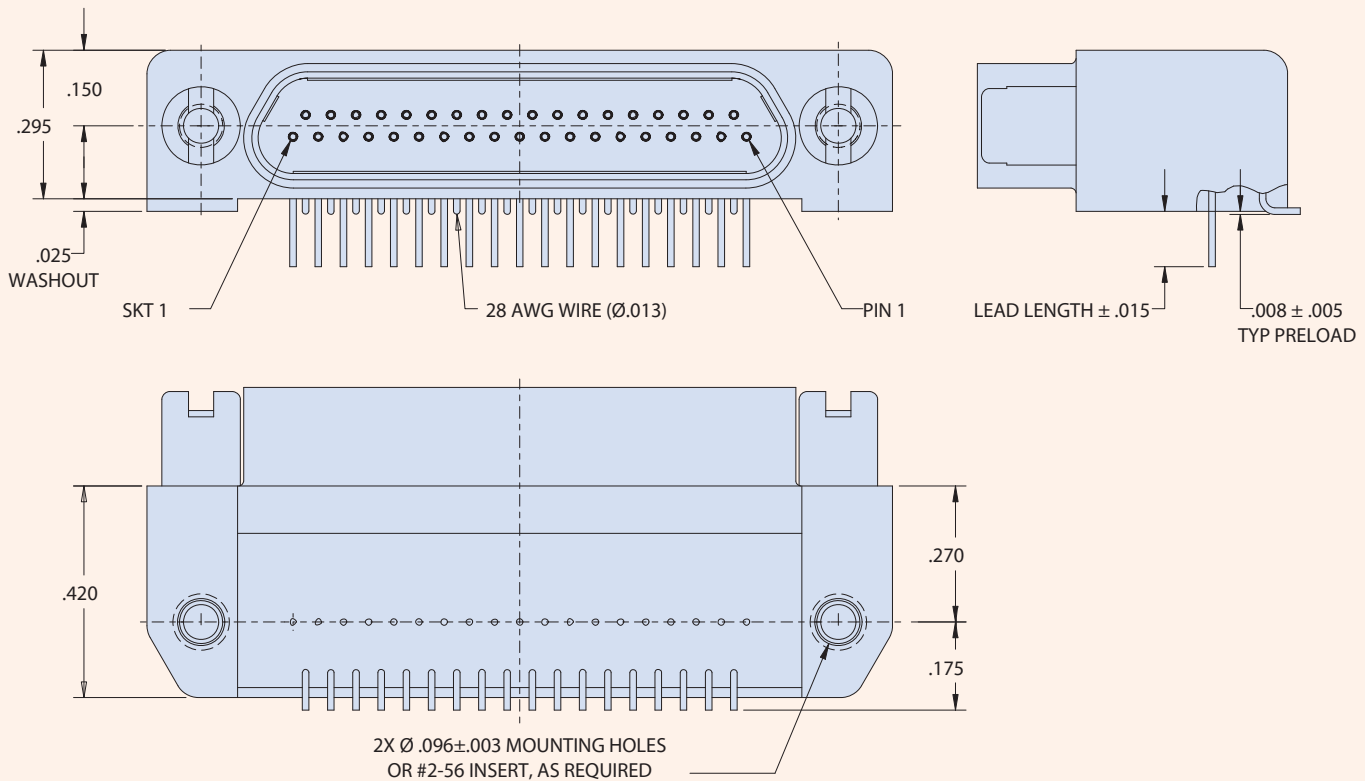

Mounting Hardware Designations		
<p>R1 thru R6 Jackposts for Rear Panel Mounting</p>	<p>P Jackpost</p>	<p>L Hex Head Jackscrew (non-removable)</p>

How-to-order GHSRPM Rear-Panel Mount Cable Assembly Connectors

How To Order High-Speed Micro-D Wired Connectors	
Sample Part Number	GHSRPM 2 R -31 P -A 8 J 1 -18 R3 N
Series	GHSRPM = Glenair High-Speed Micro-D, Rear Panel Mount
Shell Finish	2 = Nickel 5 = Gold
Insulator Material	R = PPS
Contact Layout	9, 15, 21, 25, 31, 37, 51-2, 67
Contact Type	P = Pin (Plug) S = Socket (Receptacle)
High Speed Cable Type	A = Glenair Cable 963-043-26 (100 Ohm, +105°C Max) B = Glenair Cable 963-129-28 (90 Ohm)
Discrete Wire Gage (AWG)	8 = #28 0 = #30 (J Wire Type only)
Discrete Wire Type	K = M22759/11 600 VRMS Teflon (TFE) J = M22759/33 600 VRMS Modified Cross-Linked Tefzel (ETFE)
Discrete Wire Color	1 = White 7 = Ten Color Repeating
Wire Length	Wire Length in Inches, 6 Inch Minimum
Mounting Hardware	R1 = .032" Panel R2 = .047" Panel R3 = .062" Panel R4 = .093" Panel R5 = .125" Panel R6 = .080" Panel
O-Ring Material	C = Conductive N = Non-Conductive (Nitrile)

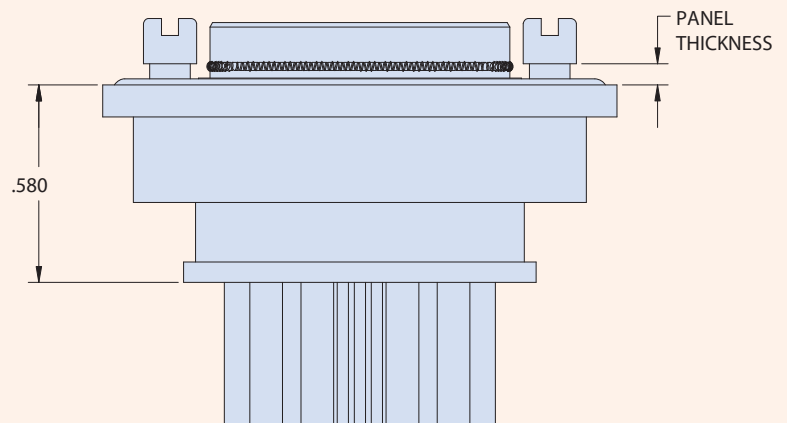
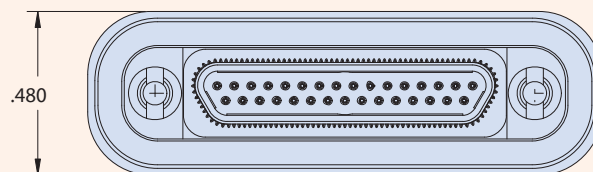
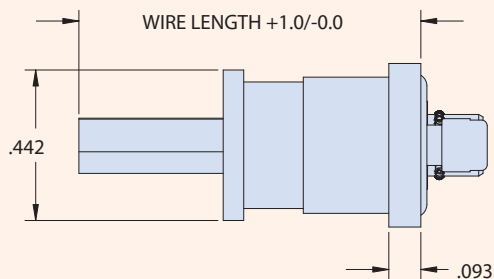

How-to-order

GHSRPM-BSS Rear-Panel Board Straight Surface Mount connectors

How To Order High-Speed Micro-D Board Straight Surface Mount Connectors	
Sample Part Number	GHSRPM 2 R -25 P BSS R3 N
Series	GHSRPM = Glenair High-Speed Micro-D, Rear Panel Mount
Shell Finish	2 = Nickel 5 = Gold
Insulator Material	R = PPS
Contact Layout	9, 15, 21, 25, 31, 37, 51-2, 67
Contact Type	P = Pin (Plug) S = Socket (Receptacle)
Termination Type	BSS = Board Straight Surface Mount
Rear Panel Mount Hardware Option	R2U = .032" Panel R3U = .047" Panel R4U = .062" Panel R5U = .094" Panel R6U = .125" Panel R7U = .080" Panel
O-Ring Material	C = Conductive N = Non-Conductive (Nitrile)

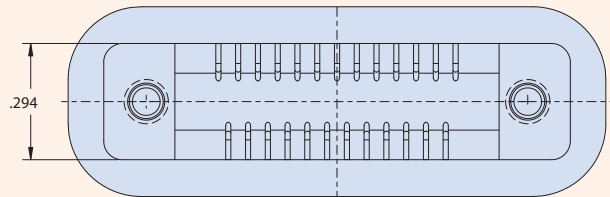
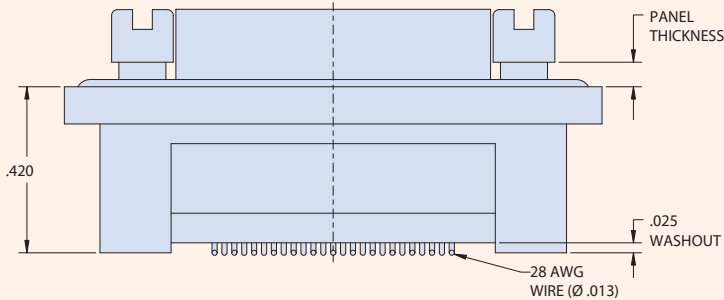
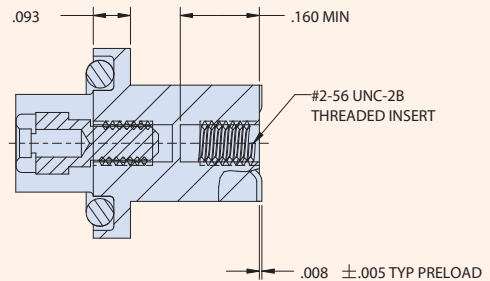
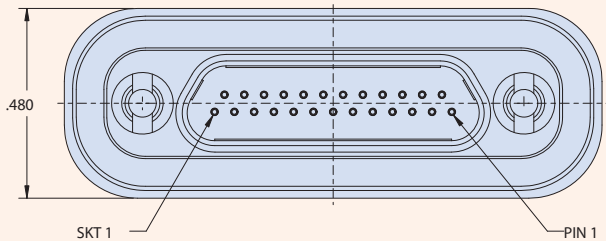

How-to-order

GHSRPM-HBR Rear-Panel Hybrid Board Right-Angle Connectors

How To Order High-Speed Micro-D Hybrid Board Right Angle Connectors											
Sample Part Number	GHSRPM	2	R	-25	P	HBR	R3	T	N	-.110	
Series	GHSRPM = Glenair High-Speed Rear-Panel Micro-D										
Shell Finish	2 = Nickel 5 = Gold										
Insulator Material	R = PPS										
Contact Layout	9, 15, 21, 25, 31, 37, 51-2, 67										
Contact Type	P = Pin (Plug) S = Socket (Receptacle)										
Termination Type	HBR = Hybrid Board Right Angle										
Rear Panel Mount Hardware Option	R1 = .032" Panel R2 = .047" Panel R3 = .062" Panel R4 = .093" Panel R5 = .125" Panel R6 = .080" Panel										
Threaded Insert Option	T = Threaded Insert in Board Mounting Hole Omit for Thru-Hole										
O-Ring Material	C = Conductive N = Non-Conductive (Nitrile)										
Right-Angle Lead Length	-.080, -.110, -.140, -.172 (Length in Inches ±.015)										

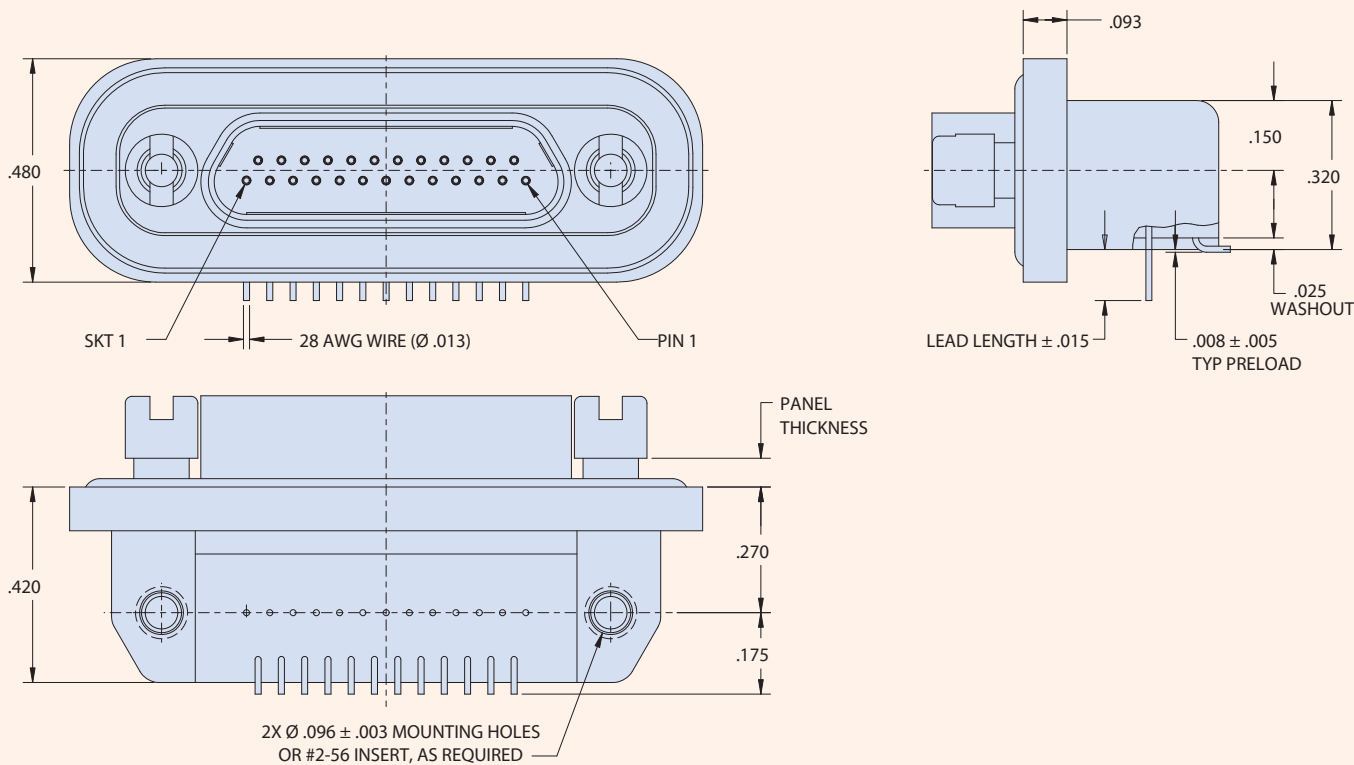

GLENAIR
SIGNATURE
FIBER OPTIC
CONNECTION
SYSTEMS

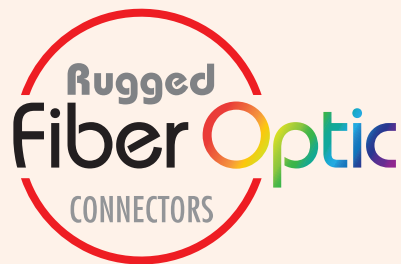

SuperNine®
Tight-Tolerance
MIL-DTL-38999 Sr. III
Fiber Optic Connection
System



The high-performance D38999 type fiber optic interconnect system with qualified MIL-PRF-29504 /4 and /5 termini, successfully deployed in hundreds of commercial and military aerospace and other applications — from F-16 upgrade systems to the revolutionary F-35 Joint Strike Fighter.

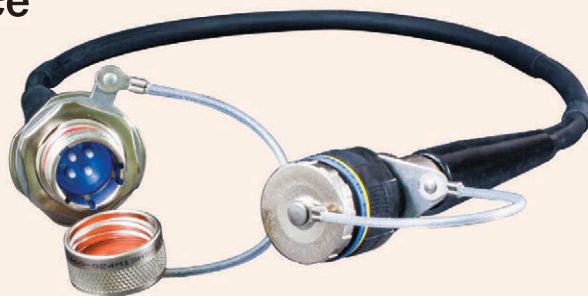

Terminated and tested point-to-point and multibranch D38999 type fiber optic cable assemblies

- Composite, aluminum and stainless steel shells available
- Qualified size #16 MIL-PRF-29504 /4 and /5 precision ceramic termini
- Singlemode and multimode fiber, from 9/125 to 1000 microns
- Ultra-low insertion loss, <.50dB typical
- From 2 to 37 Termini
- Plug and In-Line, Jam Nut and Square Flange Receptacles
- Patented MIL-DTL-38999 fiber optic test probes and adapters

SuperNine® TIGHT-TOLERANCE MIL-DTL-38999 Series III Type



Advanced fiber optic connection system



MIL-DTL-38999 type fiber optic connection system termination, inspection, test, and cleaning tools are available now from Glenair. We also offer comprehensive F/O training services for assembly and maintenance technicians.

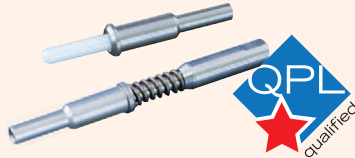

Glenair M29504/04 and /05 QPL termini are in stock and ready for immediate, same-day shipment

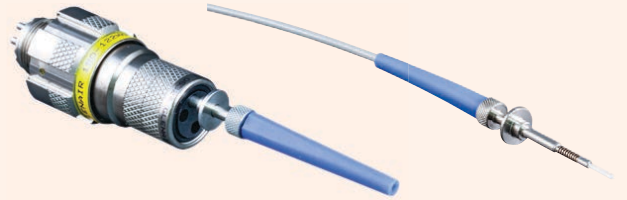

Glenair optical fiber test probes and connector adapters provide accurate and repeatable testing of MIL-DTL-38999 F/O assemblies



A complete range of metal and composite backshells and protective covers is available



Hybrid electrical/optical layouts are available including the MIL-STD-1560 17-8 layout shown above



Eye-Beam GLT termini and jumpers are easily integrated into Glenair MIL-DTL-38999 type connector packaging

MIL-PRF-29504/04 and /05 Fiber Optic Termini Performance Data	
Test Type	Performance Requirement
Operating Temperature	-55°C to +165°C (dependent on epoxy and cable)
Temperature Cycling	-65°C to +175°C
Thermal Shock	-55°C to +150°C, 5 cycles
Temperature Life	+150°C for 1,000 hours
Random Vibration	20-2,000 Hz, 42.2 g's
Shock (Half-sine Pulse)	300 g Peak Load
Mechanical Shock	MIL-S-901, Grade A, Type B, Class I
Mating Durability	500 cycles (cleaning after 100 matings)
Salt Spray	48 hours (Terminus only)
Cable Retention Force	22.0 lbs (dependent on cable construction)

Table I: Material and Finish		
Code	Material	Finish Description
M	Aluminum Alloy	Electroless Nickel
MT		Nickel - PTFE, Grey
NF		Cadmium, Olive Drab
ZNU		Zinc-Nickel, Black
ZR		Zinc-Nickel, Black (RoHS)
XM	Composite	Electroless Nickel
XMT		Nickel - PTFE, Grey
XW		Cadmium, Olive Drab
XZN		Zinc-Nickel, Black
ZL	Stainless Steel	Electro-Deposited Nickel
Z1		Passivate

INSERT ARRANGEMENTS

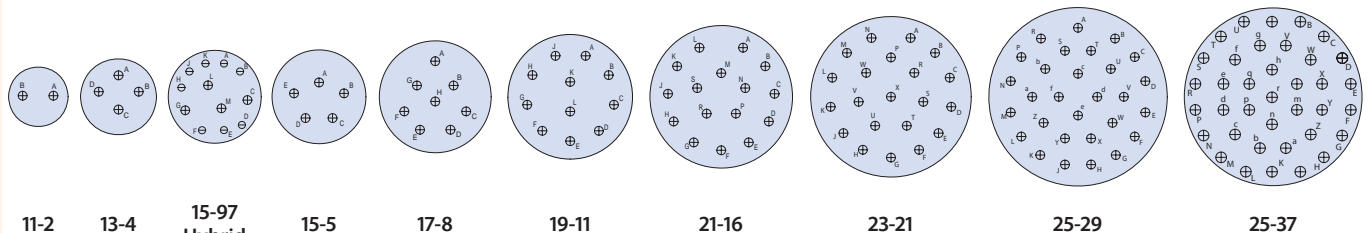

Per MIL-STD-1560. Mating face of pin insert shown.

SuperNine® TIGHT-TOLERANCE MIL-DTL-38999 Series III Type

How to order Termini and Connectors

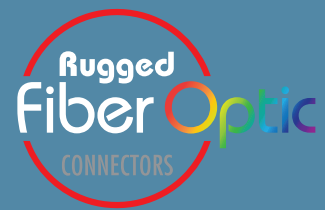

M29504/04 AND /05 TYPE, STYLE 1 PIN AND SOCKET TERMINI FOR MIL-DTL-38999 SERIES III

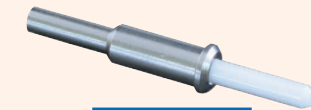

181-002-XXX
Pin Terminus



181-001-XXX
Socket Terminus



181-048-16
Size 16 Dummy Terminus
reduces weight and cost versus
standard termini

Part Number	Fiber Size Core/Cladding/ Coating (Microns)	Ferrule Hole Size	Ref. M29504/04-XXXX	Ref. M29504/05-XXXX
181-00X-125	9/125 (Singlemode)	125.5	M29504/04-4208	M29504/05-4237
181-00X-126S	9/125 (Singlemode)	126.0	M29504/04-4209	M29504/05-4238
181-00X-126	50/125 & 62.5/125	126.0	M29504/04-4210	M29504/05-4239
181-00X-127	50/125 & 62.5/125	127.0	M29504/04-4040	M29504/05-4046
181-00X-142	100/140	142.0	M29504/04-4043	M29504/05-4049
181-00X-144	100/140	144.0	N/A	N/A
181-00X-145	100/140	145.0	M29504/04-4044	M29504/05-4050
181-00X-156	62.5/125/155 (Polyimide)	156.0	M29504/04-4211	M29504/05-4240
181-00X-157	62.5/125/155 (Polyimide)	157.0	M29504/04-4212	M29504/05-4241
181-00X-173	100/140/172 (Polyimide)	173.0	M29504/04-4087	M29504/05-4088
181-00X-175	100/140/172 (Polyimide)	175.0	M29504/04-4213	M29504/05-4242
181-00X-231	200/230	231.0	N/A	N/A
181-00X-236	200/230	236.0	N/A	M29504/05-4243
181-00X-286	200/280	286.0	N/A	M29504/05-4244
181-00X-448	400/440	448.0	N/A	M29504/05-4245
181-00X-533	486/500	533.0	N/A	N/A

SUPERNINE FIBER OPTIC CONNECTORS



Part Number Development						
Sample Part Number	180-091	XW	06	-17-8	P	N
Series / Basic Part No.	D38999 Series III Type					
Material/Finish	See Material/Finish Table					
Connector Style	06 = Plug Connector					
MIL-STD-1560 Shell Size/Insert Arr.	11-2, 13-4, 15-97 (combo), 17-8, 19-11, 21-16, 23-21, 25-29, 25-37					
Insert Designation	P = Pin S = Socket					
Alternate Key Position*	A, B, C, D, E, N = Normal; Per MIL-DTL-38999					



Part Number Development						
Sample Part Number	180-091	XW	05	-17-8	P	N
Series / Basic Part No.	D38999 Series III Type					
Finish	See Material/Finish Table					
Connector Style*	05 = In-Line Receptacle					
MIL-STD-1560 Shell Size/Insert Arr.	11-2, 13-4, 15-97 (combo), 17-8, 19-11, 21-16, 23-21, 25-29, 25-37					
Insert Designation	P = Pin S = Socket					
Alternate Key Position*	A, B, C, D, E, N = Normal; Per MIL-DTL-38999					

SuperNine® TIGHT-TOLERANCE MIL-DTL-38999 Series III Type



How to order Connectors

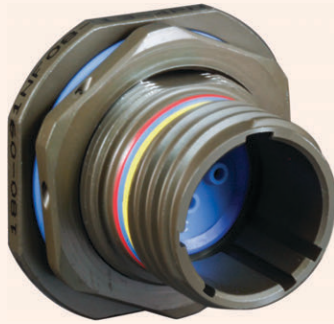

Part number development						
Sample Part Number	180-091	XW	08	-17-8	P	N
Series / Basic Part No.	D38999 Series III Type					
Material/Finish	See Material/Finish Table					
Connector Style	08 = Jam Nut Receptacle					
MIL-STD-1560 Shell Size/Insert Arr.	11-2, 13-4, 15-97 (combo), 17-8, 19-11, 21-16, 23-21, 25-29, 25-37					
Insert Designation	P = Pin S = Socket					
Alternate Key Position*	A, B, C, D, E, N = Normal; Per MIL-DTL-38999					



Part number development						
Sample Part Number	180-091	XW	H7	-17-8	P	N
Series / Basic Part No.	D38999 Series III Type					
Material/Finish	See Material/Finish Table					
Connector Style	H7 = Wall Mount Receptacle with Round Holes (Std)					
MIL-STD-1560 Shell Size/Insert Arr.	11-2, 13-4, 15-97 (combo), 17-8, 19-11, 21-16, 23-21, 25-29, 25-37					
Insert Designation	P = Pin S = Socket					
Alternate Key Position*	A, B, C, D, E, N = Normal; Per MIL-DTL-38999					



Part number development						
Sample Part Number	180-091	XW	S7	-17-8	P	N
Series / Basic Part No.	D38999 Series III Type					
Material/Finish	See Material/Finish Table					
Connector Style	S7 = Wall Mount Receptacle with Slotted Holes					
MIL-STD-1560 Shell Size/Insert Arr.	11-2, 13-4, 15-97 (combo), 17-8, 19-11, 21-16, 23-21, 25-29, 25-37					
Insert Designation	P = Pin S = Socket					
Alternate Key Position*	A, B, C, D, E, N = Normal; Per MIL-DTL-38999					

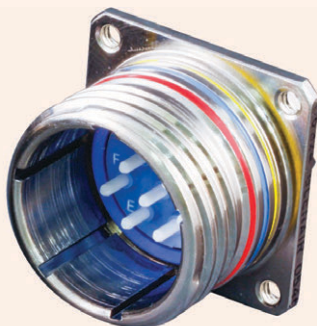

Part number development						
Sample Part Number	180-091	XW	T7	-17-8	P	N
Series / Basic Part No.	D38999 Series III Type					
Material/Finish	See Material/Finish Table					
Connector Style	T7 = Wall Mount Receptacle with Threaded Insert Holes					
MIL-STD-1560 Shell Size/Insert Arr.	11-2, 13-4, 15-97 (combo), 17-8, 19-11, 21-16, 23-21, 25-29, 25-37					
Insert Designation	P = Pin S = Socket					
Alternate Key Position*	A, B, C, D, E, N = Normal; Per MIL-DTL-38999					

GLENAIR
SIGNATURE
FIBER OPTIC
CONNECTION
SYSTEMS

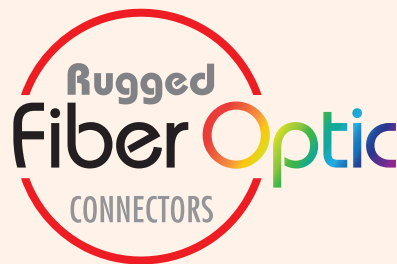

Glenair High Density (GHD): nearly double the density of standard mil-spec fiber optic designs

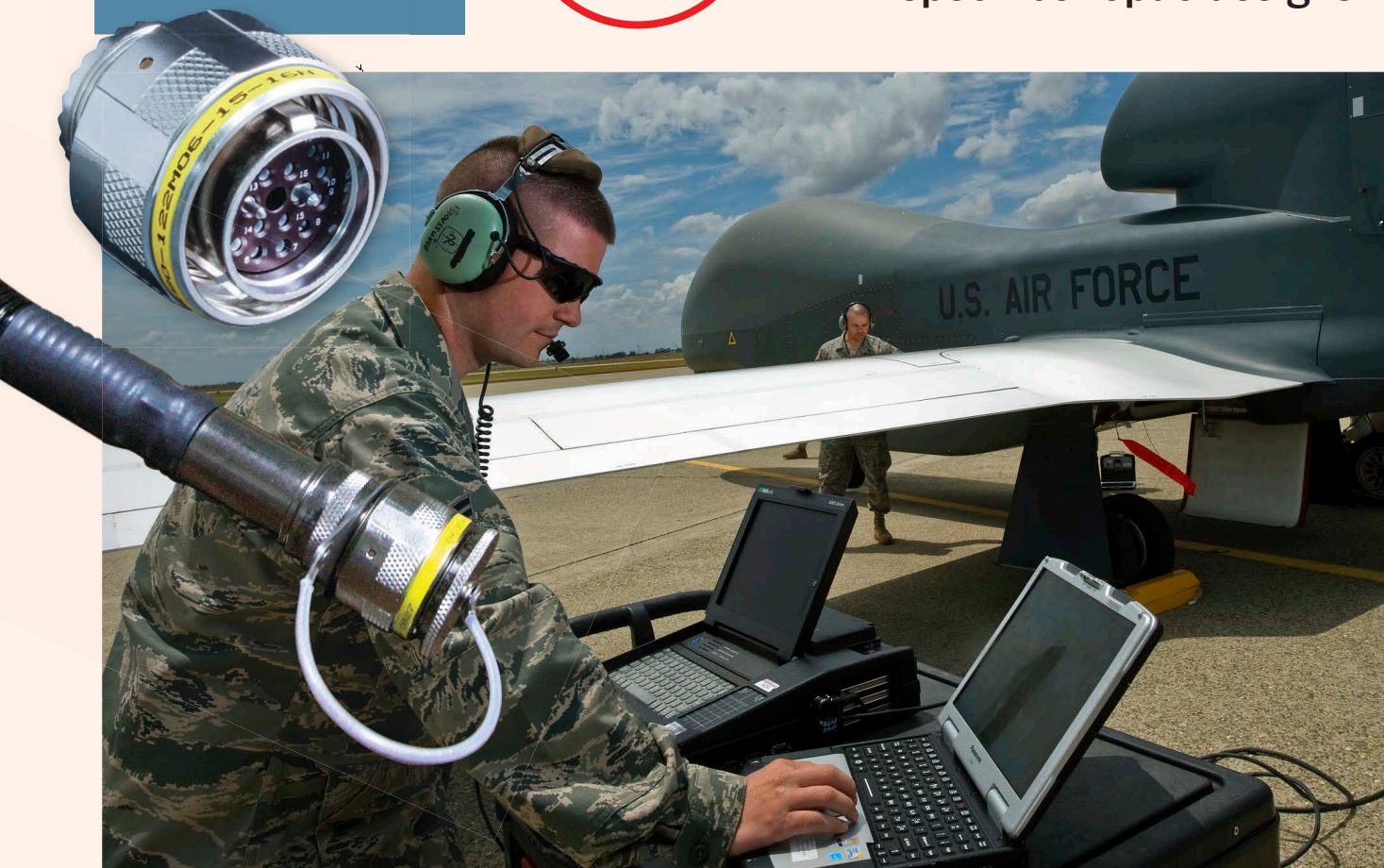

The system of choice for military and commercial air and space applications. Outstanding optical and environmental performance with nearly double the density of standard mil-spec, butt-joint solutions.

- Innovative #18 (1.25mm ferrule) front-release genderless termini accommodate 900 μ to 2.0mm jacketed fiber
- M85045/16 cable accommodation
- Composite, aluminum or stainless steel shells
- Single key termini for APC polish available
- Better optical performance than D38999 with nearly double the density
- Precision alignment sleeve retainer with integrated guide pins

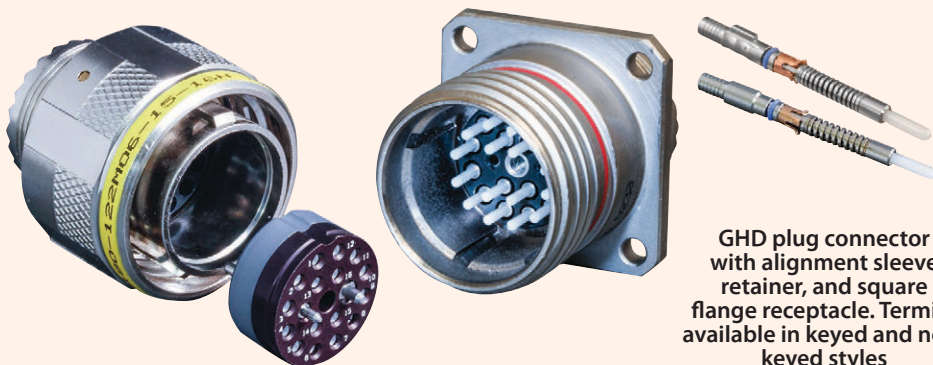

GHD plug connector with alignment sleeve retainer, and square flange receptacle. Termini available in keyed and non-keyed styles

SIZE- AND WEIGHT- SAVING Glenair High Density (GHD)



Signature HD fiber optic connection system

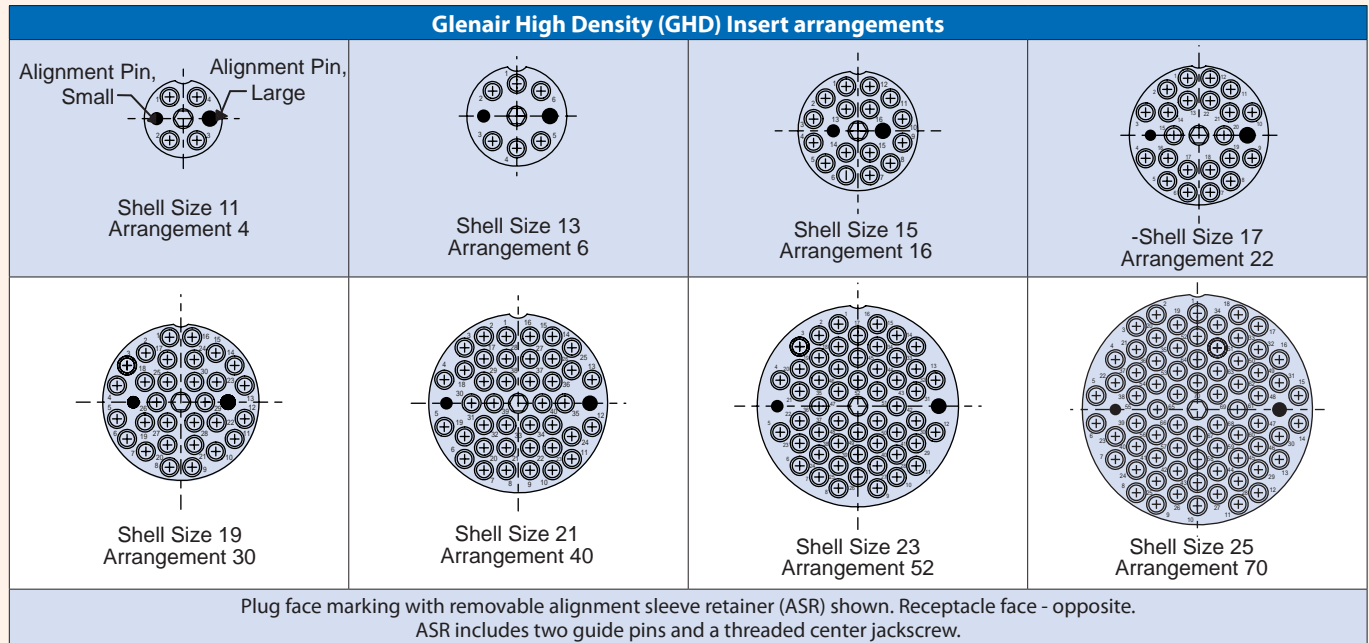

Fiber Optic Pin Termini Specifications			
Assembly Dash Number		Fiber Size	A Dia.
Keyed	Non-Keyed	Core/Cladding	[microns]
181-047-1255C	181-056-1255C	9/125 (Singlemode)	125.5
181-047-1260C	181-056-1260C	9/125, 50/125, 62.5/125	126.0
181-047-1270C	181-056-1270C	50/125, 62.5/125	127.0
181-047-1420C	181-056-1420C	100/140	142.0
181-047-1450C	181-056-1450C	100/140	145.0
181-047-1560C	181-056-1560C	62.5/125/155 (Polyimide)	156.0
181-047-1570C	181-056-1570C	62.5/125/155 (Polyimide)	157.0
181-047-1730C	181-056-1730C	100/140/172 (Polyimide)	173.0
181-047-1750C	181-056-1750C	100/140/172 (Polyimide)	175.0
181-047-2360C	181-056-2360C	200/233	236.0
181-047-2860C	181-056-2860C	200/280	286.0

Crimp Sleeve is supplied with Terminus Assembly, and may be ordered separately. For terminus less crimp sleeve, omit **C** from end of part number (e.g. 181-056-1260)

GHD Fiber Optic Part Number Reference	
Glenair Dwg. Number	Product Description
181-047	#18 Pin Terminus, Keyed for APC Polish
181-056	#18 Pin Terminus, non-keyed (standard)
181-058	#18 Dummy Terminus
180-122 (05)	In-Line Receptacle Connector
180-122 (06)	Plug Connector with Alignment Sleeve Retainer
180-122 (08)	Jam Nut Mount Receptacle Connector
180-122 (H7)	Square Flange Receptacle with Round Holes
180-122 (S7)	Square Flange Receptacle with Slotted Holes

* See fiber optic catalog for complete part number information

Table I: Material and Finish		
Code	Material	Finish Description
M	Aluminum Alloy	Electroless Nickel
MT		Nickel - PTFE, Grey
NF		Cadmium, Olive Drab
ZNU		Zinc-Nickel, Black
ZR		Zinc-Nickel, Black (RoHS)
XM	Composite	Electroless Nickel
XMT		Nickel - PTFE, Grey
XW		Cadmium, Olive Drab
XZN		Zinc-Nickel, Black
ZL	Stainless Steel	Electro-Deposited Nickel
Z1		Passivate

Pin Density Comparison: Glenair High Density Versus D38999 and M28876								
Connector Style / Size	11	13	15	17	19	21	23	25
D38999 Cavity Count	2	4	5	8	11	16	21	29/37
M28876 Cavity Count	2	4	8	N/A	N/A	N/A	31	N/A
GHD Cavity Count	4	6	16	22	30	40	52	70

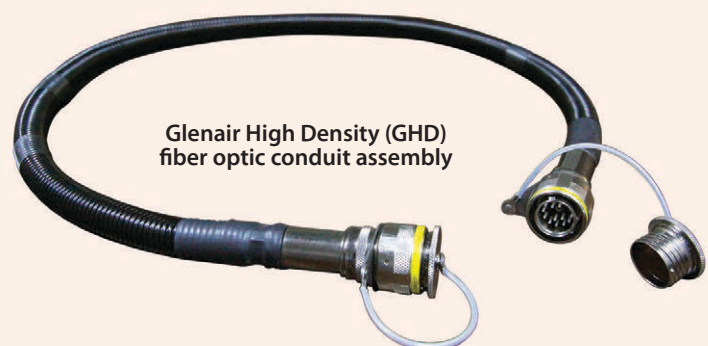

SIZE- AND WEIGHT- SAVING Glenair High Density (GHD)



Signature HD fiber optic connection system How to order connectors

Part Number Development					
Sample Part Number	180-122	NF	06	-15-16	N C
Series / Basic Part No.	Glenair High Density Fiber Optic Connector				
Material/Finish	See Material/Finish Table				
Connector Style	06 = Plug with Alignment Sleeve Retainer				
Shell Size/Insert Arr.	11-4, 13-6, 15-16, 17-22, 19-30, 21-40, 23-52, 25-70				
Alternate Key Position*	A, B, C, D, E, N = Normal				
O-Ring Option	C = Conductive O-Ring Omit = Standard O-Ring				

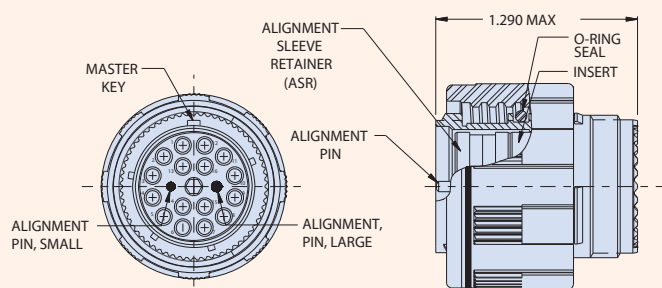

Part Number Development			
Sample Part Number	180-122	ASR	-15-16
Series / Basic Part No.	Glenair High Density Fiber Optic Connector		
Connector Style	ASR = Alignment Sleeve Retainer		
Shell Size/Insert Arr.	11-4, 13-6, 15-16, 17-22, 19-30, 21-40, 23-52, 25-70		

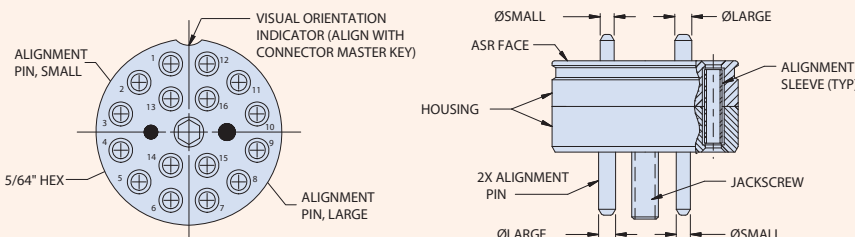

Part Number Development					
Sample Part Number	180-122	NF	08	-15-16	N
Series / Basic Part No.	Glenair High Density Fiber Optic Connector				
Material/Finish	See Material/Finish Table				
Connector Style	08 = Jam Nut Receptacle				
Shell Size/Insert Arr.	11-4, 13-6, 15-16, 17-22, 19-30, 21-40, 23-52, 25-70				
Alternate Key Position*	A, B, C, D, E, N = Normal				

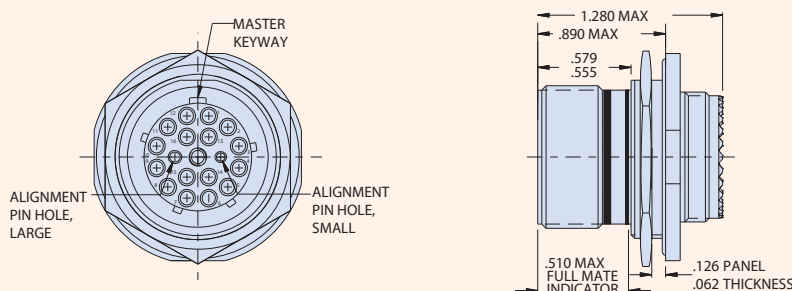

SIZE- AND WEIGHT- SAVING Glenair High Density (GHD)



Signature HD fiber optic connection system How to order connectors

Part Number Development					
Sample Part Number	180-122	NF	05	-15-16	N
Series / Basic Part No.	Glenair High Density Fiber Optic Connector				
Material/Finish	See Material/Finish Table				
Connector Style	05 = In-Line Receptacle				
Shell Size/Insert Arr.	11-4, 13-6, 15-16, 17-22, 19-30, 21-40, 23-52, 25-70				
Alternate Key Position*	A, B, C, D, E, N = Normal				

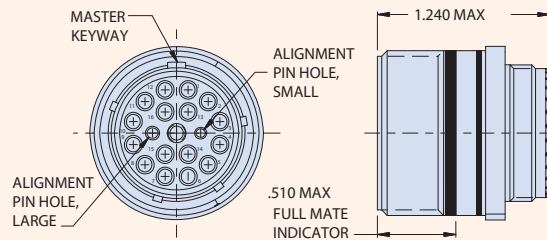

Part Number Development					
Sample Part Number	180-122	NF	H7	-15-16	N
Series / Basic Part No.	Glenair High Density Fiber Optic Connector				
Material/Finish	See Material/Finish Table				
Connector Style	H7 = Wall Mount Receptacle with Round Holes				
Shell Size/Insert Arr.	11-4, 13-6, 15-16, 17-22, 19-30, 21-40, 23-52, 25-70				
Alternate Key Position*	A, B, C, D, E, N = Normal				

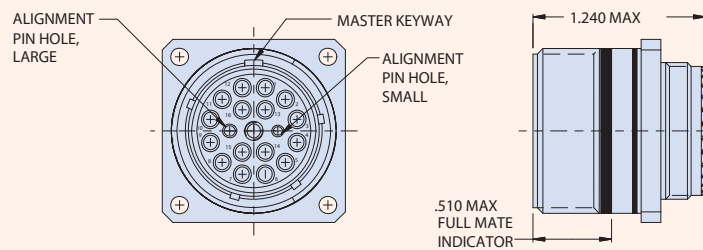

Part Number Development					
Sample Part Number	180-122	NF	S7	-15-16	N
Series / Basic Part No.	Glenair High Density Fiber Optic Connector				
Material/Finish	See Material/Finish Table				
Connector Style	S7 = Wall Mount Receptacle with Slotted Holes				
Shell Size/Insert Arr.	11-4, 13-6, 15-16, 17-22, 19-30, 21-40, 23-52, 25-70				
Alternate Key Position*	A, B, C, D, E, N = Normal				

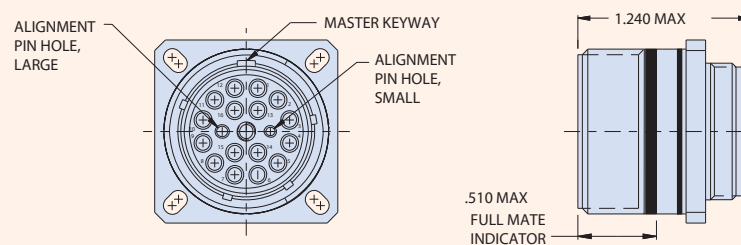

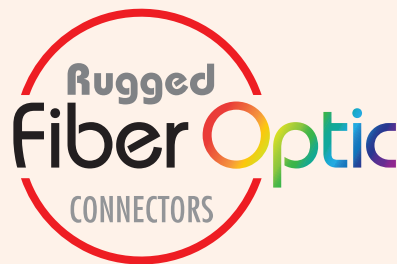

Glenair Front Release (GFR) Fiber Optic Connection System: the Fast Road to Fiber Optic Integration

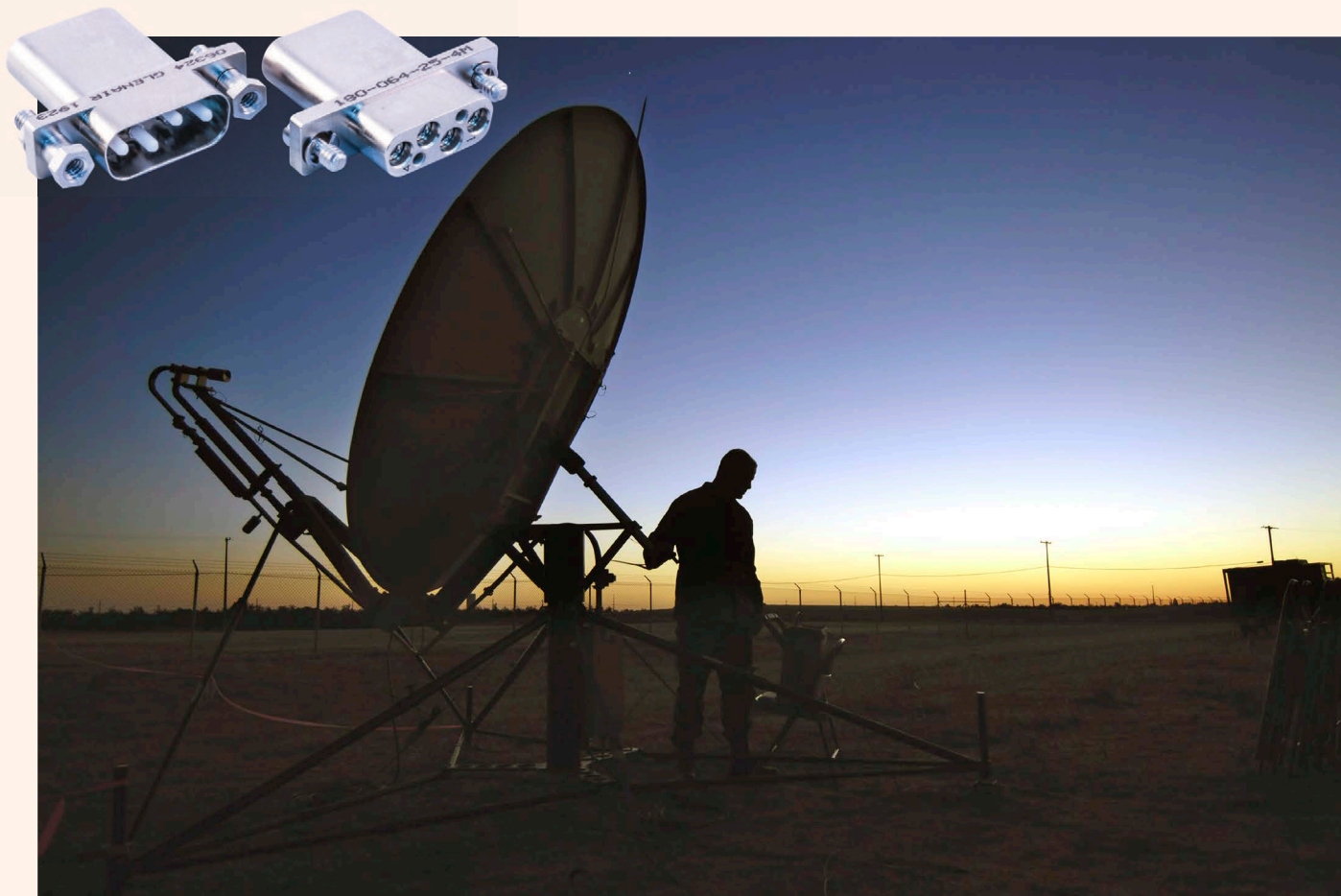

The Glenair Front Release system allows for rapid connector integration of optical media by placing retention and environmental sealing components directly on the termini. Glenair GFR enables fast design and development of unique fiber optic connector shell packages without costly tooling and engineering.

- Precision size 16 pin-socket front release termini with integrated retention clip
- Singlemode and multimode for all popular fiber sizes
- Typical insertion loss less than 0.5 dB
- Supports cylindrical and rectangular connectors
- Connector shells available in aluminum and stainless steel

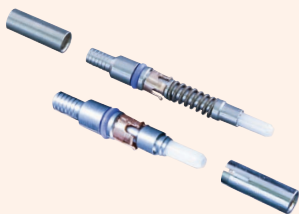

GFR fiber optic termini integration in micro miniature rectangular and circular connector packaging

Signature fiber optic connection system



Glenair Front Release (GFR) fiber optic connection systems perform at insertion loss levels equivalent to other high-performance, tactical fiber optic systems such as M29504 termini used in D38999 and M28876 connectors. The GFR system enables Glenair to integrate optical media in Micro-D and D-Subminiature shells as well as micro miniature circular packaging. Contact the factory for availability and application engineering assistance for both standard and custom fiber optic connection systems.

GFR GLENAIR FRONT RELEASE MICRO MINIATURE CIRCULAR CONNECTORS



Contact the Factory for circular connectors requiring enhanced vibration and mechanical shock performance

How To Order GFR Micro Miniature Circular Connectors			
Sample Part Number	180-132	M	06- 9-4 P A
Series	180-132 GFR Micro Miniature Circular		
Shell Size	C	Aluminum Alloy	Anodize, Black
	M		Electroless Nickel
	NF		CAD/Olive Drab over Electroless Nickel
	ZN		Zinc-Nickel/Olive Drab over Electroless Nickel
	ZNU		Black Zinc-Nickel over Electroless Nickel
Z1	Stainless Steel	Passivate	
Connector Style	04- Jam Nut w/ Wire Holes 06- Plug 08- Jam Nut Receptacle 07- Wall Mount Receptacle		
Shell Size/Insert Arr.	9-2, 9-4, 13-8, 16-12		
Contact Type	P - Pin Termini S - Socket Termini		
Key Polarization	A, B, C, D (See Table). Omit for 9-2 Arrangement which has 2 Keys/Keyways only.		

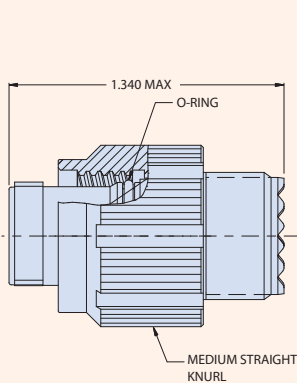

06- Plug

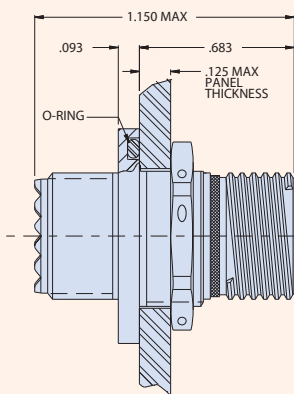

04- Jam Nut Receptacle with Wire Holes

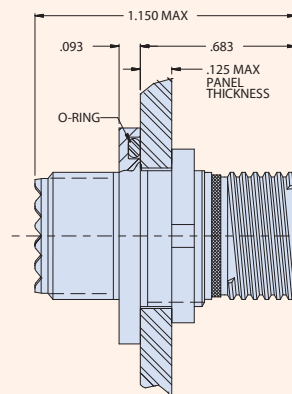

08- Jam Nut Receptacle

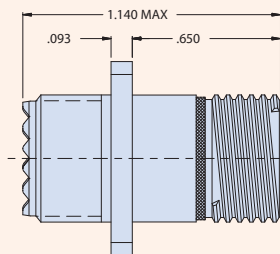

07- Wall Mount Receptacle

Key Polarization		
Position	A°	B°
A	150°	210°
B	75°	210°
C	95°	230°
D	140°	275°

Insert Arrangements (pin rear shown)			
9-2	9-4	13-8	16-12

RAPID INTEGRATION Glenair Front Release (GFR)

How to order GFR Termini



PIN TERMINI

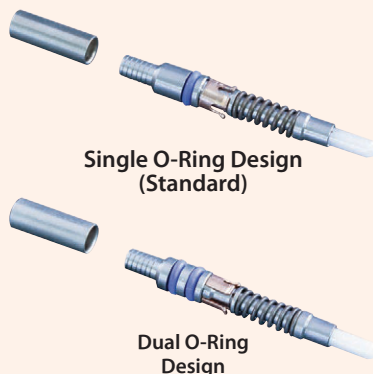

SOCKET TERMINI

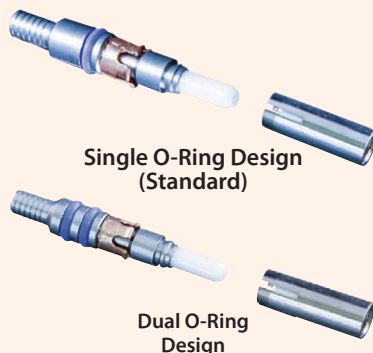

DUMMY TERMINUS



How To Order GFR Fiber Optic Termini				
Sample Part Number	181-011	-126	K	D
Series	181-012 GFR front-release pin terminus 181-011 GFR front-release socket terminus			
Dash No.	Dash No.	Ferrule Hole Ø	Typical Fiber Type	Typical Fiber Size core/cladding/coating
	-125	125.5 µm	Singlemode	9/125 µm
	-126S	126.0 µm	Singlemode	9/125 µm
	-126	126.0 µm	Multimode	50/125, 62.5/125 µm
	-142	142.0 µm	Multimode	100/140 µm
	-156	156.0 µm	Multimode	62.5/125/155 µm (Polyimide)
	-173	173.0 µm	Multimode	100/140/172 µm (Polyimide)
	-175	175.0 µm	Multimode	100/140/172 µm (Polyimide)
	-231	231.0 µm	Multimode	200/225 µm
	-236	236.0 µm	Multimode	200/230 µm
-286	286.0 µm	Multimode	200/280 µm	
-448	448.0 µm	Multimode	400/440 µm	
Alignment Sleeve (socket only)	K = Stainless Steel Sleeve Omit = Ceramic Sleeve (standard) Omit designator for pin terminus			
O-Ring Option	D = Dual O-Rings Omit = Single O-Ring (standard)			

Dummy Terminus	
181-051	Size 16 Dummy Terminus for GFR Connectors

TERMINI MATERIAL AND FINISH

Ferrule: Zirconia Ceramic
 Alignment Sleeve (socket): Zirconia Ceramic or Stainless Steel/Passivate
 Protective Cover (socket): BeCu Alloy/Nickel
 Body: Stainless Steel/Passivate
 Spring (pin): Stainless Steel/Passivate
 Bushing (pin): Stainless Steel/Passivate
 Retention Clip: BeCu Alloy
 O-Ring(s): Fluorosilicone
 Crimp Sleeve: Brass Alloy/Nickel

NOTES

Crimp sleeves are supplied with terminus assemblies. Spares may be ordered separately. See Glenair GAP-031 and GAP-031B for termination and assembly tools/procedures.

Table II: Tools and Accessories	
182-005S	Polishing Tool, socket
182-005P	Polishing Tool, pin
182-012	Crimp Tool
182-013	Insertion Tool, Straight
182-014	Insertion Tool, 90 Degree
182-015	Removal Tool
182-016	Insertion/Removal Tool, Alignment Sleeve, socket
181-011-S	Protective Cover with Ceramic Sleeve
181-011-K	Protective Cover with Stainless Steel Sleeve
265-002	Crimp Sleeve, Ø 2.2mm Max Jacket

RAPID INTEGRATION Glenair Front Release (GFR)



How to order GFR Micro-D and D-Subminiature connectors

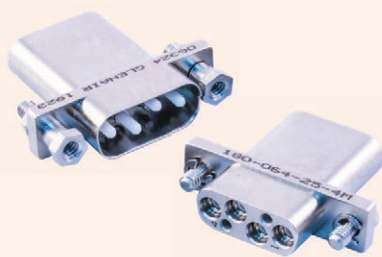

Avoid damage! Consult the factory for mating / unmating instructions

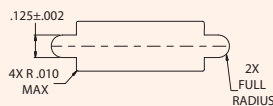

Recommended Panel Cutout

How To Order GFR Micro-D Connectors				
Sample Part Number	180-064	-25	-4	M
Series	180-064 GFR Micro-D Plug 180-063 GFR Micro-D Receptacle			
Shell Size	-9 (1 terminus max) -15 (2 termini max) -21 (3 termini max) -25 (4 termini max) -31 (5 termini max) -100 (8 termini max)			
No. of Termini	1, 2, 3, 4, 5, 8			
Material / Finish	C	Aluminum Alloy	Anodize, Black	
	M		Electroless Nickel	
	NF		CAD/Olive Drab over Electroless Nickel	
	ZN		Zinc-Nickel/Olive Drab over Electroless Nickel	
	Z1	Stainless Steel	Passivate	

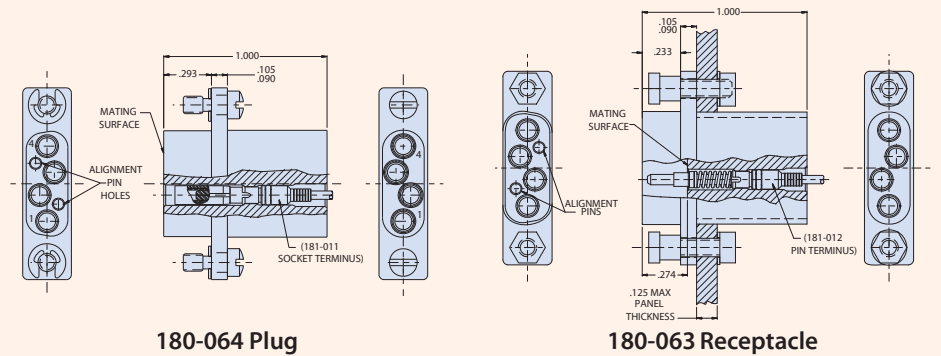

180-064 Plug

180-063 Receptacle



Avoid damage! Consult the factory for mating / unmating instructions

How To Order GFR D-Subminiature Connectors				
Sample Part Number	180-066	-15	-5	-M
Series	180-066 GFR D-Sub Plug 180-065 GFR D-Sub Receptacle			
Shell Size	-9 (4 termini max) -15 (5 termini max) -25 (8 termini max) -50 (12 termini max)			
No. of Termini	4, 5, 8, 12			
Material / Finish	C	Aluminum Alloy	Anodize, Black	
	M		Electroless Nickel	
	NF		CAD/Olive Drab over Electroless Nickel	
	ZN		Zinc-Nickel/Olive Drab over Electroless Nickel	
	Z1	Stainless Steel	Passivate	

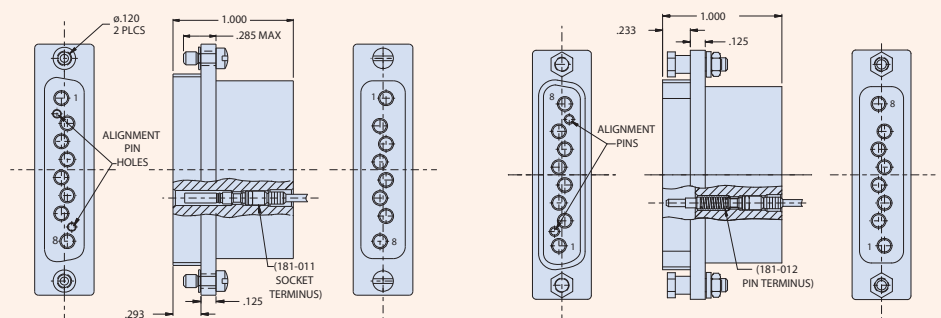

180-066 Plug

180-065 Receptacle

GLENAIR
SIGNATURE
FIBER OPTIC
CONNECTION
SYSTEMS

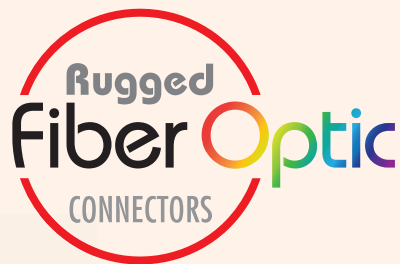

Rugged High-Density
MT Ferrule Fiber Optic
Connection System—with
Mil-Grade SuperNine®
Packaging



Ruggedized, high-density MT ferrule
fiber optics in Glenair Signature
SuperNine® aerospace-grade
MIL-DTL-38999 connectors

- Singlemode and multimode fiber
- Low insertion loss
- Environmental sealing: IP67 mated, IP68 available at interface
- Physical contact and expanded beam

ALSO AVAILABLE: EXPANDED-BEAM MT SOLUTIONS



RUGGED, HIGH-DENSITY



24
fibers



3
fibers

Up to 24 fibers in a single compact,
lightweight ferrule (7mm x 3mm)

ULTRA HIGH-DENSITY MT Ferrule



Signature fiber optic connection system: SuperNine D38999

SUPERNINE® - CONNECTOR SIZES AND INSERT ARRANGEMENTS

SuperNine® MT MIL-DTL-38999 Series III type connectors with plug-and-play MT ferrule accommodation			
<p>CONNECTOR MASTER KEY</p>			
Shell Size 11 Insert Arrangement 1 Up to 24 fibers (1 MT ferrule)	Shell Size 13 Insert Arrangement 2 Up to 48 fibers (2 MT ferrules)	Shell Size 15 Insert Arrangement 3 Up to 72 fibers (3 MT ferrules)	Shell Size 17 Insert Arrangement 4 Up to 96 fibers (4 MT ferrules)

SuperNine® MT Performance Specifications	
Test Description	Performance Requirements/Specifications
Optical Insertion Loss, Multimode Expanded Beam	-0.5 dB Typical (50/125)
Optical Insertion Loss, Multimode PC	-0.3 dB Typical (50/125)
Optical Insertion Loss, Singlemode PC	-0.3 dB Typical (9/125)
Optical Insertion Loss, Singlemode APC	-0.3 dB Typical (9/125)
Optical Back Reflection, Multimode Expanded Beam	Better than -28 dB
Optical Back Reflection, Singlemode PC	Better than -30 dB
Optical Back Reflection, Singlemode APC	Better than -60 dB
Mechanical Shock	300 G Half-sine Pulse, 3 ms Duration, 3 Times Both Direction Each Axis per TIA-455-14A
Vibration, Random	49.5 Grms at Ambient Temperature per MIL-STD-1678-3, Measurement 3201, Test Condition C, 5.3c, 8 hours exposure each axis
Mating Durability	500 Mating Cycles per TIA-455-21A
Humidity *	90%-95% RH, 96 hour Exposure per TIA-455-5C, Method A, Test Condition A
Thermal Cycle *	5 Cycles, -40°C to 85°C with 1 hour Exposure per EIA-364-32F, Condition VIII, Method A
Temperature Life *	85°C for 336 hours per TIA-455-4C

*cable and epoxy dependent

TURNKEY SUPERNINE® MT FIBER OPTIC CABLE SETS

Glenair's experienced fiber optic engineers can design, terminate, and test complex multibranch and point-to-point assemblies incorporating Glenair SuperNine® MT I/O and cable connectors with singlemode and multimode MT ferrules. Panel mount MT receptacles may be terminated to the broad range of standard commercial fiber optic interconnects for turnkey termination to board-level transceivers. Environmental MT plug assemblies are available with ruggedized backshells or in overmolded configurations. Low-profile cable overmolds provide both fiber media organization and ribbon-to-wire strain relief.



PARALLEL OPTICAL TRANSCEIVERS

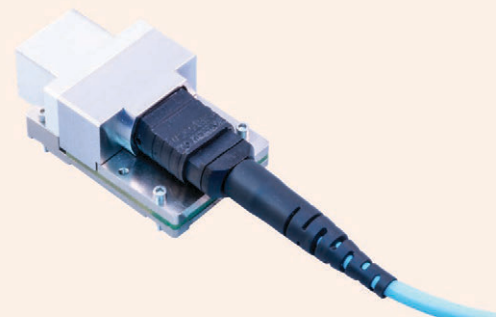

Glenair's rugged, small form-factor parallel optical transceivers are the ideal solution for board-level optical-to-electrical conversion utilizing MT fiber optic ferrules.

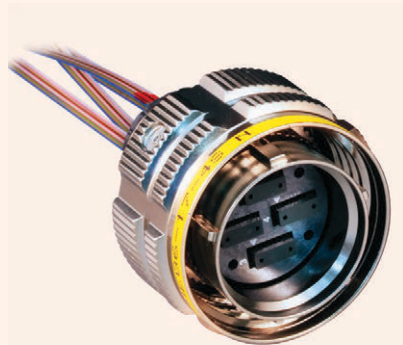

SuperNine MT Cable Plug					
Sample Part Number	183-002	ME	G6	-17-4	N
Basic Part Number	MT Ferrule Fiber Optic Connector				
Material/Finish Code	See Table I				
Connector Style	G6 = Plug with EMI/RFI ground spring				
Shell Size / Insert Arrangement	11-1, 13-2, 15-3, 17-4 Order MT ferrule kits separately, contact factory				
Alternate Key Position	A, B, C, D, E, N = Normal U = Universal (per MIL-DTL-38999)				



SuperNine MT Jam Nut Mount Receptacle					
Sample Part Number	183-002	ME	08	-17-4	N
Basic Part Number	MT Ferrule Fiber Optic Connector				
Material/Finish Code	See Table I				
Connector Style	08 = Jam nut receptacle				
Shell Size / Insert Arrangement	11-1, 13-2, 15-3, 17-4 Order MT ferrule kits separately, contact factory				
Alternate Key Position	A, B, C, D, E, N = Normal U = Universal (per MIL-DTL-38999)				



SuperNine MT In-Line Receptacle					
Sample Part Number	183-002	ME	05	-17-4	N
Basic Part Number	MT Ferrule Fiber Optic Connector				
Material/Finish Code	See Table I				
Connector Style	05 = In-line receptacle				
Shell Size / Insert Arrangement	11-1, 13-2, 15-3, 17-4 Order MT ferrule kits separately, contact factory				
Alternate Key Position	A, B, C, D, E, N = Normal U = Universal (per MIL-DTL-38999)				

How to order connectors



SuperNine MT Wall-Mount Receptacle, Standard Holes					
Sample Part Number		183-002	ME	H7	-17-4 N
Basic Part Number	MT Ferrule Fiber Optic Connector				
Material/Finish Code	See Table I				
Connector Style	H7 = Wall-mount receptacle with round holes				
Shell Size / Insert Arrangement	11-1, 13-2, 15-3, 17-4 Order MT ferrule kits separately, contact factory				
Alternate Key Position	A, B, C, D, E, N = Normal U = Universal (per MIL-DTL-38999)				



SuperNine MT Wall-Mount Receptacle, Slotted Holes, Clinch Nuts, Helicoils					
Sample Part Number		183-002	ME	S7	-17-4 N
Basic Part Number	MT Ferrule Fiber Optic Connector				
Material/Finish Code	See Table I				
Connector Style	S7 = Wall-mount receptacle with slotted holes CM = Wall-mount receptacle with metric clinch nuts CS = Wall-mount receptacle with standard clinch nuts HM = Wall-mount receptacle with metric helicoils HS = Wall-mount receptacle with standard helicoils				
Shell Size / Insert Arrangement	11-1, 13-2, 15-3, 17-4 Order MT ferrule kits separately, contact factory				
Alternate Key Position	A, B, C, D, E, N = Normal U = Universal (per MIL-DTL-38999)				

Table I - Material and Finish

Code	Material	Finish Description
ME	Aluminum Alloy	Electroless Nickel
MT		Nickel-PTFE, Grey
NF		Cadmium, Olive Drab
ZR		Zinc-Nickel, Black
TZ		Tin-Zinc, Green/Gold
XM	Composite	Electroless Nickel
XW		Cadmium, Olive Drab
Z1	Stainless Steel	Passivate
ZL		Electro-Deposited Nickel

GLENAIR
SIGNATURE
FIBER OPTIC
CONNECTION
SYSTEMS

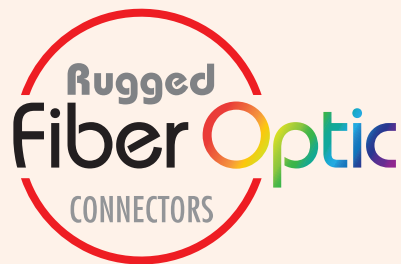

Rugged High-Density
MT Ferrule Fiber Optic
Connection System—
With Mil-Grade Miniature
Series 79 Packaging



Single-ferrule high-density
MT datalinks in Glenair
Signature Series
79 rectangular
packaging
optimize SWaP in
mission-critical
mil-aero
applications



Connector series supports
both ribbon and round
cable, as well as standard
and expanded-beam
MT ferrules

- Small form-factor, high-density fiber optic solution for rugged mil-aero applications
- Temperature tolerance from -40°C to +85°C
- Optimized for use with parallel optic transceivers in ribbon or round cable applications
- Designed for optimal low insertion loss performance in high vibration and shock environments

ULTRA HIGH-DENSITY Rugged MT Fiber Optic Connectors



Signature fiber optic connection system: miniature Series 79 packaging

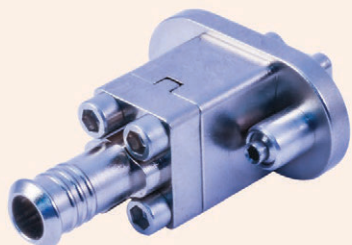

-06 plug, with retaining plate for EMI shield termination and strain relief of ribbon or round fiber cable



-S7 receptacle with standard retaining plate



-S7 receptacle with conductive EMI gasket

ABOUT SERIES 79 MT FIBER OPTIC CONNECTORS

Designed in accordance with rugged mil-aero industry specifications, the Glenair Series 79 MT fiber optic connector is the world's smallest ruggedized MT connector solution. High-density MT ferrules are packaged in precision-machined rectangular aluminum shells with electroless nickel finish, or passivated stainless steel shells for higher temperature applications. Receptacles may be equipped with optional EMI gaskets, and mate bottom-to-bottom with plug assemblies for robust resistance to vibration and shock. Designed for harsh-environment, inside-the-box use in parallel optics, fiber optic backplanes, missile systems, spacecraft and satellites, heads-up displays, and other ribbonized or flex-circuit fiber optic datalinks, the Series 79 MT delivers superior low insertion-loss performance (up to 500 mating cycles). Connectors are supplied in single (consult factory for dual and quad) MT configurations with banding platform or ultra low-profile retaining plate options.

The MT Ferrule High-Density Advantage



Up to 24 fibers in a single compact, lightweight ferrule (7mm x 3mm / .276" x .118") —same real estate as three size #16 termini side by side

PARALLEL OPTICAL TRANSCEIVERS



Glenair's rugged, small form-factor parallel optical transceivers are the ideal solution for board-level optical-to-electrical conversion utilizing MT fiber optic ferrules.

Series 79 MT Ferrule Fiber Optic Connector Performance Specifications per QTP-773 and Test Report GT-19-111

Test Description	Test Results
Optical Insertion Loss, multimode (consult factory for singlemode)	50/125 μm fiber @ 850 nm: ≤0.15 dB average; 0.31 dB typical 50/125 μm fiber @ 1300 nm: ≤0.21 dB average; 0.38 dB typical
Temperature Cycling: per TIA/EIA-455-3, Test Condition C-2	-40°C to +85°C, 5 Cycles, 56 hours Max. CIT = .25 dB; Max. IL post-test = .30 dB
Mating Durability	First 100 cycles with CIT measured every 10 cycles Max. CIT = 0.12 dB; Max. IL post-test = 0.20 dB
Mating Durability, Extended	From 101st cycle to 500th cycle with CIT measured every 25 cycles Max. CIT = 0.21 dB; Max. IL post-test = 0.30 dB
Physical Shock 1: 50g Peak, 11 ms duration, per TIA/EIA-455-14, Test Condition E	Max. CIT = 0.14 dB; Max. IL post-test = 0.42 dB; discontinuity ≤0.5 dB @ <1 us.
Physical Shock 2: 160g Peak, 4 ms duration, per MIL-STD-202, Method 213	Max. CIT = 0.04 dB; Max. IL post-test = 0.40 dB; discontinuity ≤0.5 dB @ <1 us.
Additional Physical Shock: 300g Peak, 0.5 ms duration, per MIL-STD-883E, Method 2002.4 (30 shocks total)	Max. CIT = .15 dB; Max. IL post-test = 0.20 dB; discontinuity ≤0.5 dB @ <1 us.
Vibration 1: 5-15 Hz, .12" double amplitude, 2 hours/axis (6 hours total) per MIL-STD-202, test condition 201, Sinusoidal	Max. CIT = 0.06 dB; Max. IL post-test = 0.37 dB
Vibration 2 : 20g Peak, 10-2,000 Hz, 4 hours/axis (12 hours total) per TIA-455-11, Test Condition IV, Sinusoidal	Max. CIT = 0.08 dB; Max. IL post-test = 0.43 dB
Weight	Plug with Ferrule kit 5.5 grams · Receptacle with Ferrule kit 7.5 grams

SERIES 79 MINIATURE MT Fiber Optic Connectors

How To Order Series 791 MT Ferrule Fiber Optic connectors

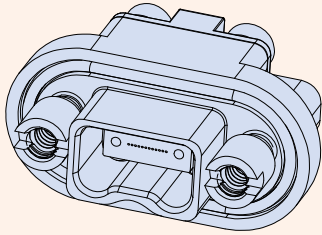

Receptacle with female MT ferrule,
available with or without EMI gasket

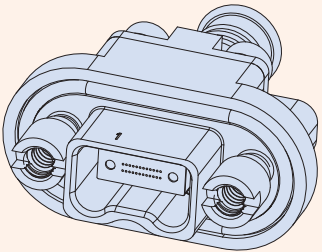

Receptacle with female MT ferrule,
retaining plate, and banding
platform

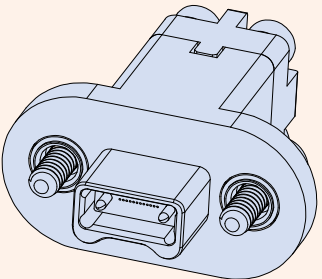

Plug with male MT ferrule and
retaining plate

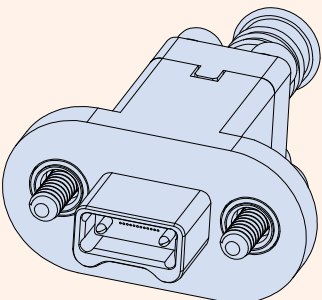

Plug with male MT ferrule with
retaining plate and banding
platform

How To Order Glenair 183-003 Series 79 MT Fiber Optic Connectors

Sample Part Number	183-003	ME	-06	-L	-1
Basic Number	Series 79 Single MT Fiber Optic Connector				
Material / Finish	ME = Al Alloy / Electroless Nickel ZR = Al Alloy / Zinc Nickel, Black NF = Al Alloy / Cadmium, O.D. Z1 = Stainless Steel / Passivate				
Connector Type	-06 = Plug (used with male MT ferrule) -07 = Receptacle (used with female MT ferrule) -S7 = Receptacle with EMI gasket (used with female MT ferrule)				
Mounting Hardware	Hardware for PLUGS		Rear Panel Mount Jackposts for RECEPTACLES:		
	-L = Hex Head Jackscrew, non-removable		-X = for .031" panel thickness		
	-B = Thru-Hole		-W = for .047" panel thickness		
			-V = for .062" panel thickness		
			-T = for .094" panel thickness		
Retaining Plate / Banding Platform	-1 = 12 or 24 channel without banding platform -2 = 12 or 24 channel with banding platform for EMI shield termination and strain relief				

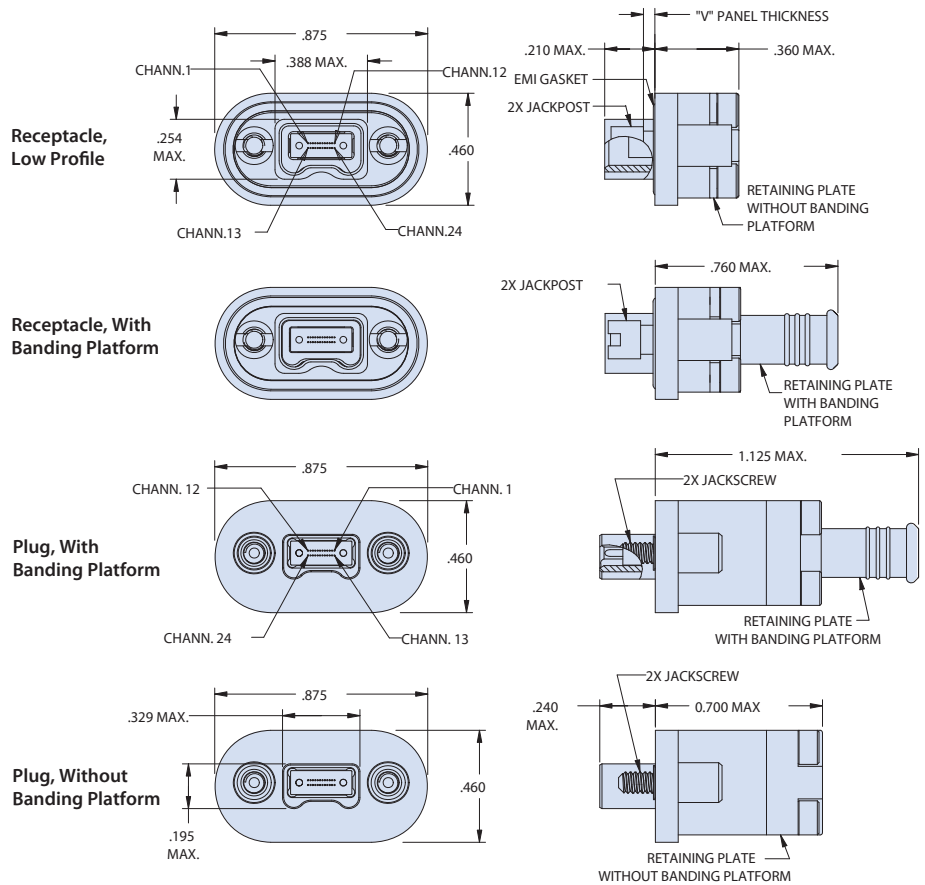

MATERIAL/FINISH/NOTES

Mounting hardware: stainless steel / passivated

EMI gasket (optional): conductive silicone

Additional materials, finishes, connector configurations (dual and quad layouts), and hardware options are available, consult factory

SERIES 79 MINIATURE MT Fiber Optic Connectors



How To Order MT Ferrule Kits and Series 79 MT to MT Ferrule Cable Assembly

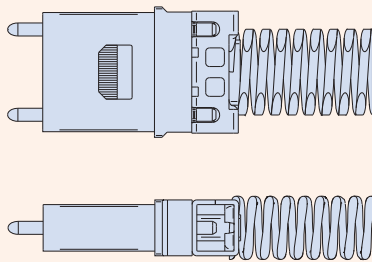

MATERIAL/FINISH

- Ferrule: Polyphenylene Sulfide Resin
- Pin Clamp, Spring: Stainless Steel
- Boot: TPE

How To Order MT Ferrule Kits					
Sample Part Number		181-133	-126	-12	P
Basic Part Number	MT Ferrule kit				
Fiber type	-126, -1253, -1253A (See Table I)				
Number of Fibers	-12, -24 (See Table I)				
Ferrule Style	P = Male (use with Plug) S = Female (use with Receptacle)				

Table I						
Dash No.	Fiber Type	End Face	Fiber Size Core/Cladding	No. of Fibers	Ferrule Identification	Pin Clamp Identification (Male Kit only)
-126	MM	PC	50/125	12	M-ME12	1 Through Hole
			62.5/125	24	M-ME24	
-1253	SM	PC	9/125	12	E-E12	2 Through Holes
-1253A	SM	APC	9/125	12	E-E12	2 Through Holes

How To Order Series 79 MT Ferrule Fiber Optic Cable Assemblies											
Sample Part Number		FA07364	-06	-17	ME	-B4	-50	-L	-1	-0036	-L
Basic Number	Series 79 MT Ferrule Fiber Optic Cable Assembly										
A Connector Type	-06 = Sr. 79 Plug (used with male MT ferrule) -07 = Sr. 79 Receptacle (used with female MT ferrule) -S7 = Sr. 79 Receptacle with EMI gasket (used with female MT ferrule)										
B Connector Type	-06 = Sr. 79 Plug (used with male MT ferrule) -07 = Sr. 79 Receptacle (used with female MT ferrule) -S7 = Sr. 79 Receptacle with EMI gasket (used with female MT ferrule) -12 = ST Connector -13 = FC Connector -14 = SC Connector -15 = GC Connector -16 = LC Connector -17 = MT Connector (male) -18 = MT Connector (female) -19 = MTP Connector (male) -20 = MTP Connector (female)										
Material / Finish (-06, -07, -S7)	ME = Al Alloy, Electroless Nickel NF = Al Alloy, Cad/Olive Drab ZR = Al Alloy, Zinc-Nickel, Black Z1 = Stainless Steel, Passivate										
Fiber Qty. / Type	-B2 = 12 bare ribbon fibers -B4 = 24 bare ribbon fibers (Multimode only) -R2 = 12 round ribbon fibers -R4 = 24 round ribbon fibers (Multimode only)										
Fiber Size	-09 = 9.3/125 Singlemode -50 = 50/125 Multimode -62 = 62.5/125 Multimode										
Mounting Hardware	Plug -L = Hex head jackscrew, non-removable -B = Thru-hole Receptacle -X = Rear-panel jackpost, .031" thickness -W = Rear-panel jackpost, .041" thickness -V = Rear-panel jackpost, .062" thickness -T = Rear-panel jackpost, .094" thickness										
Banding Platform (-06, -07, -S7)	-1 = without banding platform -2 = with banding platform										
Length	In inches (e.g. -0036 = 36 inches)										
Protective Cover	L = supplied less covers Omit = supplied with covers										

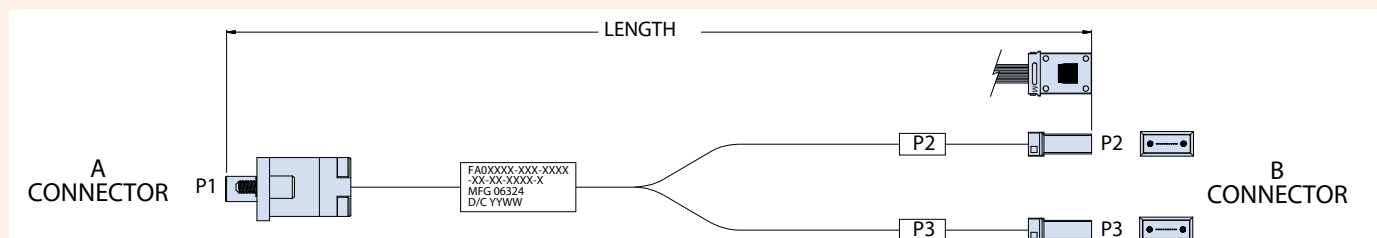

Optical performance note: Insertion loss to be less than 1.5 dB when measured at 1310 nm wavelength for singlemode, or when measured at 850 nm for multimode

RUGGEDIZED
PCB-MOUNT
PHOTONICS



Ruggedized High-Density, High Signal Integrity **Photonic Transceiver Modules**—up to 25Gbps Per Channel



Glenair PCB mount transceiver modules are ruggedized equivalents to SFP transceivers but with mechanical design suited to the harsh temperature and vibration environments found in free space, satellite, and other Mil-Aero applications. Optional Digital Monitoring Interface (DMI) IAW SFF 8472. High bandwidth parallel optical modules with MT datalink technology. Radiation tolerant.

- Smallest footprint available
- Jet fighter and space launch shock and vibration tested
- High-speed board interconnection — no soldering required
- CML 100 Ohm differential input and output
- -40°C to +85°C operating temperature range

RUGGEDIZED PCB-MOUNT MODULES FOR ETHERNET, HIGH-SPEED VIDEO, AND STORAGE

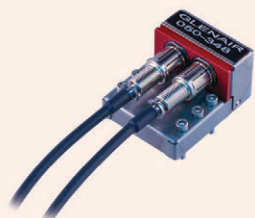

EMI shielded and radiation-tolerant transceivers



Dual transceivers, quad transmitters, quad receivers



Bi-directional transceivers

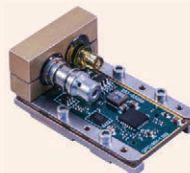

Aerospace-grade DWDM transceivers for free-space optical links



Small form-factor, high-vibration high-temperature tolerant

Parallel Optic Transceivers • RF-Over-Fiber Transceivers • Bi-Directional Transceivers • Radiation-Tolerant Designs

PARALLEL OPTIC TRANSCEIVERS

Glenair parallel optic transceivers deliver up to 25Gbps per channel high-speed data in free space optics (FSO) applications. Heat tolerant and compatible with conduction cooling for space applications, the transceivers are supplied as discrete printed circuit board mount devices, or with turnkey MTP jumpers or ruggedized MT fiber optic interconnections.

- 4 X 14 to 4 X 25 Gbps per fiber (up to 100 Gbps)
- 12-channel Tx and Rx with 10Gbps/channel
- Compatible with MTP optical connector
- Supports 12-fiber ribbon cable
- SiGe and GaAs optoelectronic ICs
- Hermetic opto-electronic hybrid
- Conduction-cooling for space applications
- 46 Grms, 650G shock
- -40°C to +85°C case temp
- Heavy ion radiation-tested

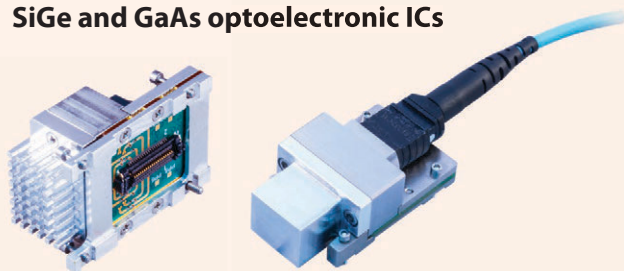

Convection cooling (left) and conduction cooling (right) designs as well as custom heat dissipation designs are available.
 050-346 parallel optical transceiver, 4 X 10 – 14 Gbps
 0500-3007 parallel optical transceiver, 0.1 – 25 Gbps

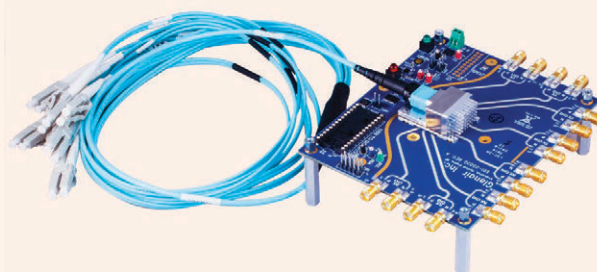

Available evaluation boards: 050-346 parallel optic transceiver with MT-to-39029 fiber optic terminations

RF-OVER-FIBER TRANSCEIVERS

Radio Frequency over Fiber systems integrate wireless radio frequency (RF) transmissions and fiber optic datalinks into a single system. Benefits include lower transmission loss (attenuation) as well as reduced sensitivity to electromagnetic noise. Glenair ruggedized, low-noise, shielded RF-over-Fiber solutions have a 2MHz to 3.5GHz RF bandwidth and can be embedded inside-the-box or incorporated into standalone copper-to-fiber media converters for environmental applications.

- 2MHz – 3.5 GHz antenna signal distribution
- High-frequency units in excess of 20 GHz
- High-vibration PCB mount solution
- -40°C to +85°C operating case temperature
- High Spurious Free Dynamic Range (SFDR) link
- APC fiber optic contact standard
- Integrated high-speed PIN photo diode and low-noise RF amplifiers

RF over Fiber PCB-Mount Component Selection Guide

050-400 PCB Mount RF-over-Fiber Transceiver 20MHz to 3.5 GHz	050-404 PCB Mount RF-over-Fiber Transmitter 2 MHz – 3.5 GHz	050-405 PCB Mount RF-over-Fiber Receiver 2 MHz – 3.5 GHz	050-406 PCB Mount RF-over-Fiber Transmitter 2 MHz – 3.5 GHz Low-Noise configuration	050-407 PCB Mount RF-over-Fiber Receiver 2 MHz – 3.5 GHz Low-Noise configuration

PCB-Mount Modules	Glenair Part Number	100BASE-FX	1000BASE-SX	1000BASE-LX	1000BASE-LX10	1000BASE-EX	1000BASE-BX10	10GBASE-SR	10GBASE-LR	10GBASE-LX4	40GBASE-SR4	100GBASE-SR4	HDMI	DVI/ARINC 818	SMPTE HD-SDI	SMPTE 3G-SDI	1x Fibre Channel	2x Fibre Channel	4x Fibre Channel	8x Fibre Channel	BUS	OTHER
	ETHERNET											VIDEO			FIBRE CHANNEL				BUS	OTHER		
050-315		•											•	•			•	•	•		•	
050-316		•											•	•			•	•	•		•	
050-317		•											•	•			•	•	•		•	
050-318			•	•									•				•				•	
050-319			•	•									•				•	•			•	
050-320			•	•									•	•			•	•	•		•	
050-321	•																					•
050-324			•	•	•								•				•	•	•		•	
050-325			•	•	•								•				•	•	•		•	
050-327						•							•	•			•	•	•	•		
050-328							•						•	•			•	•	•	•		
050-331														•	•							
050-332														•	•							
050-333		•											•	•			•	•	•		•	
050-336		•											•	•			•	•	•		•	
050-337		•											•	•			•	•	•		•	
050-340													•				•					
050-341							•						•	•			•	•	•	•		
050-342			•	•													•	•				
050-343									•				•	•			•	•	•	•	•	
050-346						•			•								•	•	•	•		
050-348		•												•			•	•	•		•	
050-352	•																					•
050-354			•	•										•			•	•	•		•	
050-356			•	•										•			•	•			•	
050-357														•	•							
050-358														•								
050-360		•											•	•			•	•	•		•	
050-361		•											•	•			•	•	•		•	
050-362		•											•	•			•	•	•		•	
050-363		•											•	•			•	•	•		•	
050-364		•											•	•			•	•	•		•	
050-369						•	•						•	•			•	•	•	•		
050-373		•											•	•			•	•	•		•	
050-374		•											•	•			•	•	•		•	
050-375		•											•	•			•	•	•		•	
050-376								•					•	•			•	•	•	•	•	
050-379														•								
050-385		•											•	•			•	•	•		•	
050-386						•							•	•			•	•	•	•		
050-389														•	•							
050-394						•								•			•					
050-397*						•								•			•					
0500-3007											•			•			•	•	•	•		
0500-3011						•								•			•	•	•	•		

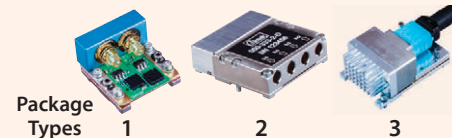

DESCRIPTION	DATARATE (Gbps)	WAVE LENGTH (nm)	LASER TYPE	RECEIVER TYPE	MAX. DISTANCE (km)	PACKAGE TYPE
Transceiver	0.1 - 5	850	VCSEL	PIN TIA	0.5	1
Dual Transmitter	0.1 - 5	850	VCSEL	N/A	0.5	1
Dual Receiver	0.1 - 5	850	N/A	PIN TIA	0.5	1
Transceiver	0.1 - 1.25	1310	FP	PIN TIA	10	1
Dual Transmitter	0.1 - 2.5	1310	FP	N/A	10	1
Dual Receiver	0.1 - 4.25	1310	N/A	PIN TIA	10	1
Transceiver	0.05 - 0.2	1300	LED	PIN TIA	20	1
Transceiver	0.1 - 2.5	1310	DFB	PIN TIA	40	1
Dual Transmitter	0.1 - 2.5	1310	DFB	N/A	40	1
Transceiver	1 - 10.5	850	VCSEL	PIN TIA	0.4	1
Transceiver	1 - 10.5	1310	DFB	PIN TIA	10	1
SMPTE Dual Transmitter	1.5 - 2.97	850	VCSEL	N/A	1	1
SMPTE Dual Receiver	1.5 - 2.97	850	N/A	PIN TIA	1	1
Dual Transceiver	0.1 - 5	850	VCSEL	PIN TIA	0.5	2
Quad Transmitter	0.1 - 5	850	VCSEL	N/A	0.5	2
Quad Receiver	0.1 - 5	850	N/A	PIN TIA	0.5	2
BIDI Transceiver	0.1 - 1.25	1310/1550	FP/FP	PIN TIA	4	1
BIDI Transceiver	1 - 10	1270/1330	DFB/DFB	PIN TIA	10	1
CWDM Transceiver	0.1 - 2.5	CWDM	DFB	PIN TIA	20	1
CWDM Transceiver	1 - 10.5	CWDM	DFB	PIN TIA	10	1
Parallel Optical Transceiver	4 X 10 - 14	850	VCSEL	PIN TIA	0.5	3
EMI Shielded Transceiver	0.1 - 5	850	VCSEL	PIN TIA	0.5	1
Transceiver	0.05 - 0.2	1310	FP	PIN TIA	10	1
Transceiver	2.5 - 5	1310	FP	PIN TIA	10	1
CWDM Dual Transmitter	0.1 - 2.5	CWDM	DFB	N/A	10	1
SMPTE Dual Receiver	1.5 - 2.97	1250-1600	VCSEL	PIN TIA	10	1
SMPTE CWDM Dual Transmitter	1.5	CWDM	DFB	N/A	10	1
Radiation-Tolerant Dual Transmitter	0.1 - 5	850	VCSEL	N/A	0.5	1
Radiation-Tolerant Dual Receiver	0.1 - 5	850	VCSEL	PIN TIA	0.5	1
Radiation-Tolerant Transceiver	0.1 - 5	850	VCSEL	PIN TIA	0.5	1
Radiation-Tolerant Quad Transmitter	0.1 - 5	850	VCSEL	N/A	0.5	2
Radiation-Tolerant Quad Receiver	0.1 - 5	850	VCSEL	PIN TIA	0.5	2
Transceiver MMF TX · SMF RX	1 - 10	850 TX 1310 RX	VCSEL	PIN TIA	10	1
Dual-Transceiver (4 mounting screws)	0.1 - 5	850	VCSEL	PIN TIA	0.5	2
Quad Transmitter (4 mounting screws)	0.1 - 5	850	VCSEL	N/A	0.5	2
Quad Receiver (4 mounting screws)	0.1 - 5	850	N/A	PIN TIA	0.5	2
CWDM Dual Transmitter	1 - 10	CWDM	DFB	N/A	10	1
SMPTE CWDM Transceiver	1.5	CWDM	DFB	PIN TIA	10	1
Radiation-Tolerant Dual Transceiver	0.1 - 5	850	VCSEL	PIN TIA	0.5	2
Dual Transmitter	1 - 10.5	850	VCSEL	PIN TIA	0.4	1
SMPTE Transceiver	1.5 - 2.97	850	VCSEL	PIN TIA	1	1
BIDI Transceiver	0.1 - 2.5	1310/1490	DFB/DFB	PIN TIA	10	1
BIDI Transceiver	0.1 - 1.25	1310/1550	DFB/DFB	PIN TIA	10	1
Parallel Optical Transceiver	4 X 25	850	VCSEL	PIN TIA	0.1	3
DWDM EML FSO Transceiver	11.3	DWDM	EML	PIN TIA	40	1



Ruggedized **Size #8** **Photonic Transmitter and** **Receiver Contacts and** Connectors for Ethernet, Video and High-Speed Data



Size 8 photonic contacts transmit and receive differential CML or LVPECL electrical signals over Multimode fiber optic cable. Transmitters consist of a 850nm VCSEL laser or 1300nm LED with temperature compensation circuit. Receivers consist of a PIN Photo Detector, a Transimpedance Amplifier with automatic gain control circuit, and a Limiting Amplifier.

Differential output data signals are LVPECL or CML compatible.



Patented photonic contacts integrate into Glenair circular and rectangular connectors including SuperNine® (D38999 Series III), ARINC 801, ARINC 404, and others.

- Fast and Gigabit Ethernet, DVI, HDMI video capable transmitter and receiver-equipped contacts
- ARINC 664, 801, 803, 804 and 818 standard compliant
- Link distances up to 550 meters, multimode
- Single, 3.3 V power supply
- For use in ARINC 600 and other size #8 cavity-equipped connectors
- Current offerings include 1.25mm ARINC 801 and 2.5mm ELIO® solutions

RUGGEDIZED

Photonic Contacts and Connectors for Ethernet, Video and High-Speed Data



050-301 SIZE 8 CAVITY OPTO-ELECTRONIC CONTACTS, 100MBPS TO 5GBPS, MMF, 3.3V

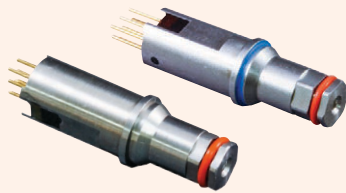

050-301
Radiation Tolerant

- Front-release, front-insert, front-removable Size #8 OE converter designed for ARINC 600
- ARINC 664, 801, 803, 804, and 818 Standard Compliant
- Data rates from 100Mbps to 5.00Gbps
- Supports Fast and Gigabit Ethernet, AFDX, 1x/2x Fibre Channel, DVI, DHMI, SFPDP, Serial Rapid I/O (sRIO)
- 100 ohms differential CML inputs with Tx Fault and Tx Disable
- Link distances up to 550 meters with multimode 50/125µm or 62.5/125 µm fiber
- Single 3.3V power supply
- ARINC 801 1.25mm ceramic fiber ferrule
- Solutions available in 38999 style connectors
- -40°C to +85°C Operating Case Temperature
- Evaluation fixtures available

050-307 SIZE 8 CAVITY OPTO-ELECTRONIC CONTACTS, 100MBPS TO 5GBPS, MMF, 3.3V



050-307
Radiation Tolerant

- Front-release, front-insert, front-removable Size #8 OE converter designed for ARINC 600
- ARINC 664, 801, 803, 804, and 818 Standard Compliant
- Data rates from 100Mbps to 5 Gbps
- Supports Fast and Gigabit Ethernet, AFDX, 1x/2x Fibre Channel, DVI, DHMI, SFPDP, Serial Rapid I/O (sRIO)
- 100 ohms differential CML inputs with Tx Fault and Tx Disable
- Link distances up to 550 meters with multimode 50/125µm or 62.5/125 µm fiber
- Single 3.3V power supply
- ELIO 2.5mm ceramic fiber ferrule
- Solutions available in 38999 style connectors
- Mates with ELIO 2.5mm Termini
- -40°C to +85°C Operating Case Temperature
- Evaluation fixtures available
- Compatible with Souriau ELIO AQ6S Quadrax Adapter

050-367 SIZE 8 CAVITY OPTO-ELECTRONIC CONTACTS, 3G-SDI AND HD-SDI, MMF, 3.3V



050-367
(patented)

- SMPTE EG 34:2004 Compliant to Pathological Conditions CASE 1, CASE 2 and CASE 3.
- SMPTE ST 297:2015 (3G-SDI & HD-SDI)
- SMPTE 424 Compliant (3G-SDI)
- SMPTE 292 Compliant (HD-SDI)
- SFP Compatible Electrical Input signal levels
- 850nm VCSEL support 3G-SDI & HD-SDI
- Industry standard CML input and outputs that make for simple integration on customer host PCB
- Front-release, front-insert, front-removable
- Fits size 8 quadrax cavity for ARINC 600
- Solutions available in 38999 style connectors
- -40°C to +85°C Operating Case Temperature
- Evaluation fixtures available

050-399 SIZE 8 CAVITY OPTO-ELECTRONIC CONTACTS, DC TO 1 MBPS, MMF, 3.3V

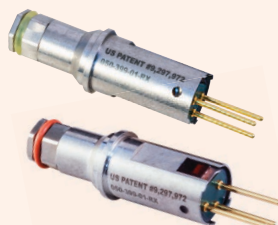

050-399
(patented)

- Front-release, front-insert, front-removable Size #8 OE converter designed for ARINC 600
- ARINC 664, 801, 803, 804, and 818 Standard Compliant
- Data rates from DC to 1 Mbps
- Supports RS232, RS422, and RS485 data rates
- DC coupled transmitter and receiver
- Link distances up to 2Km
- Single 3.3V power supply
- ARINC 801 1.25mm ceramic fiber ferrule
- Solutions available in 38999 style connectors
- -40°C to +85°C Operating Case Temperature
- Evaluation fixtures available

RUGGEDIZED
PHOTONIC
CONTACTS AND
CONNECTORS



Small Form-Factor, Harsh-
Environment **Photonic**
Contacts and Connectors
for Box I/O Fiber-to-Copper
Media Conversion

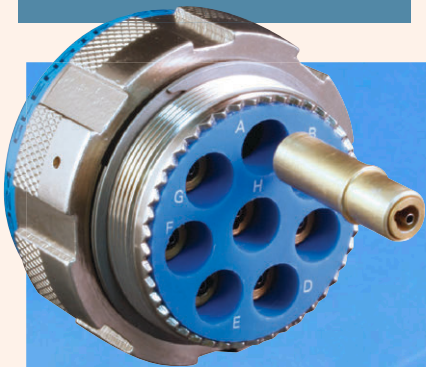

Special size #8 cavity adapters facilitate construction of standard fiber optic plug connectors that intermate with size #8 optoelectronic transceiver contacts



Glenair size #8 optoelectronic contacts are easily housed in a range of circular and rectangular connectors for fast/gigabit Ethernet, DVI and HDMI video, and other high-speed data transfer protocols. Special size #8 cavity adapters are available to enable construction of compatible plug connectors on the cable side.

- 2.5mm ELIO® solution for multimode Ethernet, video, and high-speed data applications
- 1.25mm ARINC 801 multimode fiber optic termini solution for Ethernet, video, and high-speed data
- Hybrid high-speed layouts with Size #8 Optoelectronic contacts and Glenair Signature El Ochito high-speed Octaxial contacts



Glenair SuperNine D38999 Series III type optoelectronic connectors populated with size #8 contacts, ready for immediate assembly in cable or I/O to circuit board applications

ELIO® is a registered trademark of SOURIAU

Photonic Contacts and Connectors for Ethernet, Video and High-Speed Data



Optoelectronic Connector Selection Guide		
	050-313	Optoelectronic Transceiver, MIL-DTL-38999 Type 2.5mm ELIO® Compatible 100Mbps – 4.25Gbps
	050-304	D38999 Series III Type Active Receptacle Connector with Glenair Size 8 Optoelectronic Contacts 050-304 CS Wall Mount, Clinch Nut 050-304 00 Wall Mount, Slotted 050-304 07 Jam Nut 059-0001 - D38999 Size 8 Cavity Adapter Kit (Includes ARINC 801 Style Terminus)
	050-392	D38999 Series III Type Active Hybrid Receptacle Connector with Glenair Size 8 Optoelectronic and Electrical Contacts 050-392 07 Jam Nut 059-0001 - D38999 Size 8 Cavity Adapter Kit (Includes ARINC 801 Style Terminus)
	050-355	D38999 Series III Type Active Receptacle Connector with Glenair Size 8 Optoelectronic Contacts. 050-355 CS Wall Mount, Clinch Nut 050-355 00 Wall Mount, Slotted 050-355 07 Jam Nut 059-0001 - D38999 Size 8 Cavity Adapter Kit (Includes ARINC 801 Style Terminus)
	0500-3004	D38999 Series III Type Active Hybrid Receptacle Connector with PCB standoffs, Glenair Size 8 Optoelectronic contacts, and electrical contacts Compatible with 050-301 and 050-367 contacts 059-0001 - D38999 Size 8 Cavity Adapter Kit (Includes ARINC 801 Style Terminus)
	0500-3005	D38999 Series III Type Active Hybrid Receptacle Connector with Glenair Size 8 Optoelectronic Contacts, and El Ocho contacts. 0500-3005 CS Wall Mount, Clinch Nut 0500-3005 00 Wall Mount, Slotted 0500-3005 07 Jam Nut
	0500-3001	D-Sub Active Receptacle Connector with Glenair Size 8 Optoelectronics Contacts. Compatible 050-301, 050-367, 050-399, and 0500-3015 contacts 1.25 Gbps – 5.00 Gbps / HD-SDI and 3G-SDI / DC to 50 Mbps
	0500-3024	D-Sub Active Receptacle Connector with 2 × Glenair Size 8 Optoelectronics Contacts. Compatible 050-301 and 050-367 contacts 1.25 Gbps – 5.00 Gbps
	0500-3034	D-Sub Active Receptacle Connector with 2 × Glenair Size #8 Optoelectronics Contacts. Compatible 050-301, 050-367, 050-399, and 0500-3015 contacts 1.25 Gbps – 5.00 Gbps / HD-SDI and 3G-SDI / DC to 50 Mbps



**MISSION-CRITICAL
INTERCONNECT
SOLUTIONS**

Glenair, Inc.

1211 Air Way • Glendale, California • 91201-2497
Telephone: 818-247-6000 • Fax: 818-500-9912 • sales@glenair.com
www.glenair.com

**Glenair Power
Products Group**

20 Sterling Drive
Wallingford, CT
06492

Telephone:
203-741-1115
Facsimile:
203-741-0053
sales@glenair.com

Glenair UK Ltd

40 Lower Oakham Way
Oakham Business Park
Mansfield, Notts
NG18 5BY England

Telephone:
+44-1623-638100
Facsimile:
+44-1623-638111
sales@glenair.co.uk

Glenair Microway Systems

7000 North Lawndale Avenue
Lincolnwood, IL
60712

Telephone:
847-679-8833
Facsimile:
847-679-8849

Glenair Nordic AB

Gustav III : S Boulevard 42
SE-169 27 Solna
Sweden

Telephone:
+46-8-50550000
sales@glenair.se

Glenair GmbH

Schaberweg 28
61348 Bad Homburg
Germany

Telephone:
06172 / 68 16 0
Facsimile:
06172 / 68 16 90
info@glenair.de

Glenair Iberica

C/ La Vega, 16
45612 Velada
Spain

Telephone:
+34-925-89-29-88
Facsimile:
+34-925-89-29-87
sales@glenair.es

Glenair Italia S.p.A.

Via Del Lavoro, 7
40057 Quarto Inferiore –
Granarolo dell'Emilia
Bologna, Italy

Telephone:
+39-051-782811
Facsimile:
+39-051-782259
info@glenair.it

Glenair France SARL

7, Avenue Parmentier
Immeuble Central Parc #2
31200 Toulouse
France

Telephone:
+33-5-34-40-97-40
Facsimile:
+33-5-61-47-86-10
sales@glenair.fr

Glenair Korea

6-21Tapsil-ro 58beon-gil
Giheung-gu, Yongin-si
Gyeonggi-do
Republic of Korea

Telephone:
+82-31-8068-1090
Facsimile:
+82-31-8068-1092
sales@glenair.kr

